

Operating Manual

**FS-30/FS-52/
FS-60/FS-100**
Monitor Speaker

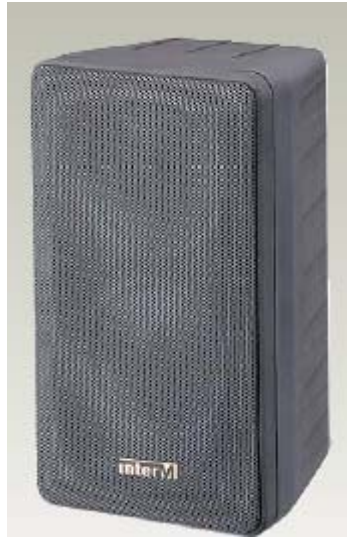

©Copyright 2004 Inter-M Corporation

interM

Contents

Welcome	3
Unpacking	3
Warnings	3
Monitor Speaker	5
Features	5
Setup and Operation.....	6
Connecting your Speaker System	7
Choosing the Correct Speaker Cable.....	7
Speaker Connection Procedures	7
Maintaining Proper Polarity	7
Choosing the Correct Amplification.....	7
Using Multiple Loudspeakers.....	8
Directional Curves	9
Specifications.....	10

Welcome

A personal welcome to you from the management and employees of Inter-M

Thank you for purchasing this fine Inter-M product. All of us here at Inter-M are dedicated to providing you with the highest quality products and the best value.

We sincerely trust this product will provide you with years of satisfactory service, but if anything is not to your complete satisfaction, we will endeavor to make things right.

Welcome to Inter-M, and thank you for becoming a part of our worldwide extended family!

Unpacking

Although your FS-Series Monitor Speaker is neither complicated nor difficult to operate, we recommend you take a few minutes to read this brief manual and familiarize yourself with the important information regarding product features, setup and operation.

We strongly recommend you retain the original packaging. In the unlikely event the product must be returned for servicing, the original packaging (or reasonable equivalent) is required.

Warnings

Environment

Never place this product in an environment that could alter its performance or reduce its service life. Such environments are usually characterized by high levels of heat, dust, moisture, or vibration.

Safety

1. Read these instructions carefully.
2. Follow all instructions.
3. Keep all warnings.
4. Clean only with a damp cloth.
5. Install only in accordance with the instructions in this manual.
6. Do not install near any heat sources such as radiators, heat registers, stoves, or other devices (including amplifiers) that produce heat.
7. Use only the attachments/accessories specified.

8. Use only with a cart, stand, tripod, bracket, or table specified, or sold with the apparatus. When a cart is used, use caution when moving the cart/apparatus combination to avoid overturning.
9. Unplug this apparatus during lightning storms or when unused for long periods of time.
10. Refer all servicing to qualified service personnel. Servicing is required when the apparatus has been damaged in any way, such as power supply cord or plug is damaged, liquid has been spilled or objects have fallen into the apparatus, the apparatus has been exposed to rain or moisture, does not operate normally, or has been dropped.

<div style="border: 2px solid black; padding: 5px; margin-bottom: 10px;"> <div style="display: flex; justify-content: space-between; align-items: center;"> <div style="text-align: center;"> <p>CAUTION</p> <p>RISK OF ELECTRIC SHOCK DO NOT OPEN</p> </div> </div> <p style="text-align: center; margin-top: 5px;">CAUTION: TO REDUCE THE RISK OF ELECTRIC SHOCK, DO NOT REMOVE COVER (OR BACK). NO USER-SERVICEABLE PARTS INSIDE. REFER SERVICING TO QUALIFIED SERVICE PERSONNEL.</p> </div> <div style="margin-top: 10px;"> <p>WARNING</p> <p>To prevent fire or shock hazard, do not expose the unit to rain or moisture.</p> <p><small>*Do not install this equipment in a confined space such as a book case or similar unit. *The apparatus shall not be exposed to dripping or splashing and no objects filled with liquids, such as vases, shall be placed on the apparatus. *Worded: "WARNING FOR YOUR PROTECTION PLEASE READ THE FOLLOWING-WATER AND MOISTURE: Unit should not be used near water (e.g. near a bathtub, washbowl, kitchen sink, laundry tub, in a wet basement, or near a swimming pool, etc). Care should be taken so that objects do not fall and liquids are not spilled into the enclosure through openings."</small></p> </div>	<div style="margin-bottom: 10px;"> <p>This symbol is intended to alert the user to the presence of uninsulated "dangerous voltage" within the product's enclosure that may be of sufficient magnitude to constitute a risk of electric shock to persons.</p> </div> <div style="margin-bottom: 10px;"> <p>This symbol is intended to alert the user to the presence of important operation and maintenance (servicing) instructions in the literature accompanying the appliance.</p> </div> <div style="margin-bottom: 10px;"> <p>Caution: To prevent electric shock do not use this (polarized) plug with an extension cord, receptacle or other outlet unless the blades can be fully inserted to prevent blade exposure.</p> </div> <div style="border: 1px solid black; padding: 5px;"> <p>Attention: Pour prévenir les chocs électriques ne pas utiliser cette fiche polarisée avec un prolongateur, une prise de courant ou une autre sortie de courant, sauf si les lames peuvent être insérées à fond sans en laisser aucune partie à découvert.</p> </div>
--	--

FS-30/FS-52/FS-60/FS-100 Monitor Speaker

Features

Superior Performance

- The FS-series Monitor Speakers are designed for high-fidelity professional sound reproduction.

Switchable Impedance

- The FS-30/FS-60/FS-100 models incorporate an impedance switch for connection to a low impedance (8 Ω) or high impedance distributed (70V/100V) system.

Overload Protection

- The FS-52 model incorporates an electronic overload circuit to protect the tweeter.

High Efficiency Two-Way Design

- Full-range two-way speaker system for high efficiency PA system performance.

Easy Installation

- Installs easily with included bracket.

Setup and Operation

Your FS-Series Monitor Speakers may be used as free-standing speakers, or attached to a wall or other secure surface with the supplied mounting bracket. The illustration below shows the preferred method of securing the speaker.

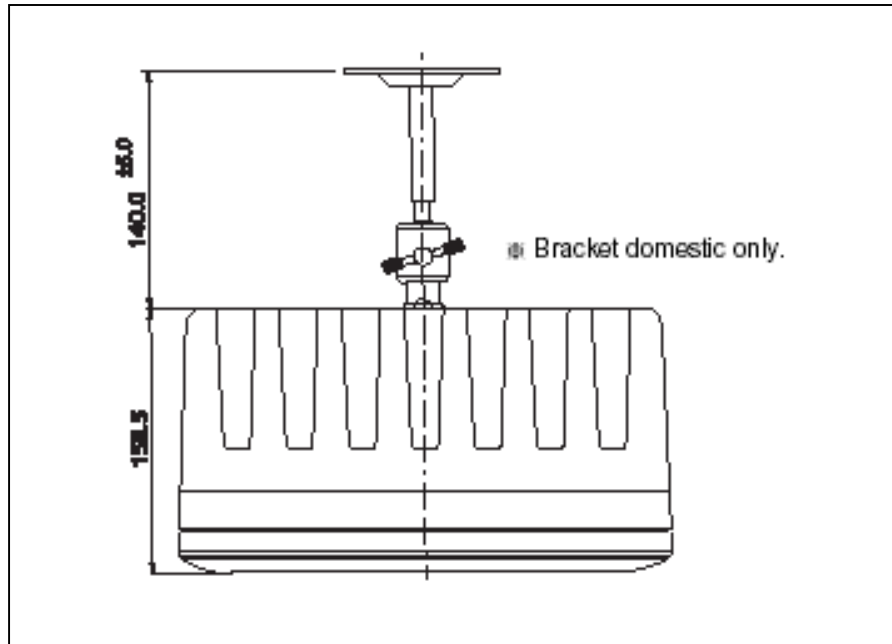

WARNING: under no circumstances should any loudspeaker be mounted or suspended in a public place unless the mounting method has been approved and certified by a qualified engineer. Failure to properly secure the system can result in damage to the unit or personal injury.

Connecting your Speaker System

Always switch off the power to the amplifier before connecting speakers.

Choosing the Correct Speaker Cable

It is important to choose cabling designated for audio use and good quality connectors. Using guitar cable or zip cord (designed for lamps and other electrical use) or poor quality connectors will degrade your loudspeakers' audio performance. For distributed loudspeaker systems, we recommend stranded twisted pair speaker cable with an overall vinyl jacket (plenum rated when installed in required installations).

Always use the appropriate gauge of speaker cable. For cable runs of less than 25 feet (7.5 meters), 18-gauge cable is adequate. For longer cables, we suggest 16-gauge stranded cable.

Speaker Connection Procedures

After removing approximately 10mm (1/4-inch) of insulation from the ends of the speaker cables, twist the strands tightly and then twist together with the distribution cable(s), using an appropriate cable connector.

Make certain the wires do not protrude from the cable connector and touch any metal on the speaker chassis, or any other adjacent metal.

Maintaining Proper Polarity

It is very important to wire your speakers consistently in order to maintain proper polarity. All quality cables are manufactured with clear markings to identify the different conductors – normally by color-coding, printed markings, or textured ribbing on the cable's jacket material. Failing to do so will cause your speakers to operate out of phase, resulting in significantly reduced low-frequency output from your system.

Choosing the Correct Amplification

When selecting an amplifier for use with your distributed speaker system, it is important to choose an amplifier which has sufficient power output.

Choosing an amplifier that does not have adequate rated power may result in pushing the amp beyond its limits, producing distortion or "clipping" of the signal. This can irritate the listener and may cause damage to the speaker.

Choosing an amplifier that is over-powered can result in over-driving the speaker system.

Using Multiple Loudspeakers

It is important to consider the overall speaker load (impedance) when connecting distributed speaker systems to an amplifier. Some distributed loudspeakers are marked in load impedance; others show the wattage taps. Whatever the case, it is easy to compute the total impedance (or wattage load) that is possible for a given amplifier.

Directional Curves

FS-30/FS-60/FS-100

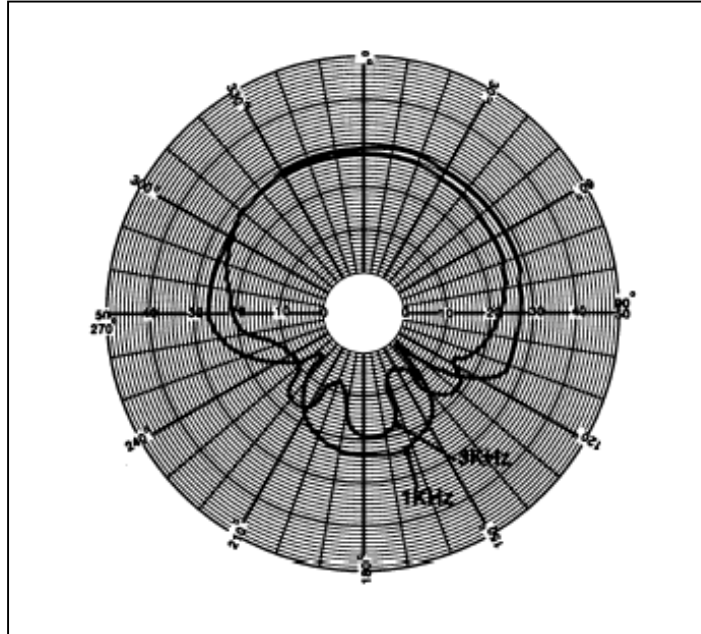

FS-52

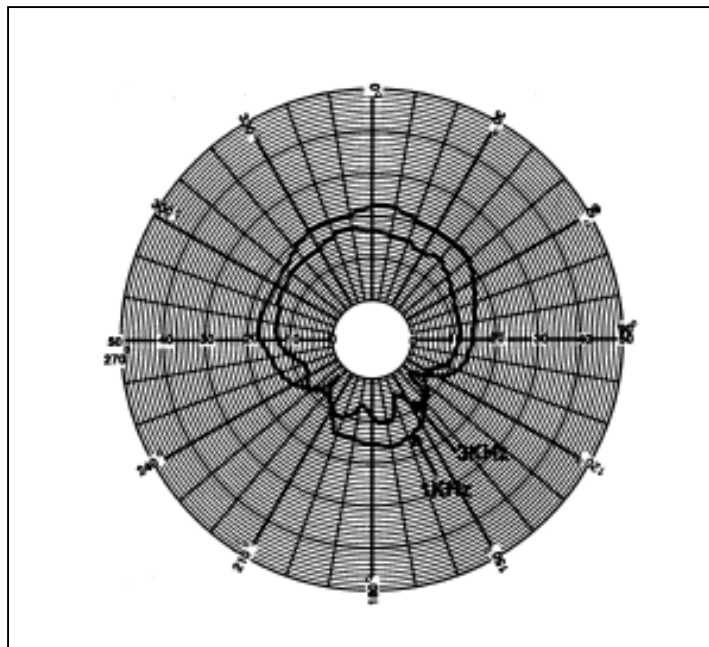

Specifications

ELECTRICAL

Rated Input

FS-30	30W
FS-52	50W
FS-60	60W
FS-100	100W

Input Impedance

FS-30	8 Ω /330 Ω
FS-52	8 Ω /200 Ω
FS-60	8 Ω /167 Ω
FS-100	8 Ω /100 Ω

Frequency Response

180Hz-13kHz

GENERAL

Dimensions

175(W) x 300(H) x 158.5(D) mm
6.89(W) x 11.8(H) x 6.24(D) in.

Specifications and design subject to change without notice for improvements.



Inter-M, Ltd. (Korea) began operations in 1983.

Since then, Inter-M has grown to become one of the largest manufacturers of professional audio and commercial sound electronics equipment in the world.

Inter-M has gained worldwide recognition for its own branded products, as well as private label manufacturing of electronics sold under other names (OEM).

The company is no longer just a Korean company, but rather a global company that is truly international in scope, with factories and offices in Korea and China, and sales and marketing operations located in Japan, Europe, and the U.S.A.

With more than 850 employees around the globe, Inter-M is well-poised for further growth and expansion.

INTER-M AMERICAS, INC.

1 EAST BEACON LIGHT LANE, CHESTER, PA, USA 19013-4409

TEL: (610) 874-8870, FAX: (610) 874-8890

Home Page:<http://www.inter-m.net>, E-mail: service@inter-m.net

INTER-M Corporation

SEOUL OFFICE: 653-5 BANGHAK-DONG, DOBONG-KU, SEOUL, KOREA

TEL: 82-2-2289-8140~8, FAX: 82-2-2289-8149

Home Page:<http://www.inter-m.com>, E-mail: export@inter-m.com