

GS-50BT/50WT

interM

FASHION SPEAKER



GS-50BT

GS-50WT

Bracket(FSB-1) : Option

FEATURES

- Versatile and Unobtrusive Speaker Designed for a Variety of Applications
- Electronic Overload Circuit to Protect Tweeter
- Rated Output : 20W
- 4Ω or 70V/100V Impedance
- Two-Way Speaker : 2 1/4" Cone Type Tweeter and 5" Free-edge Woofer
- Frequency Response : 90Hz-18kHz
- Color Coded Push-Type Connection Terminals
- Compatible with Optional FSB-1 Bracket

SPECIFICATIONS

- ELECTRICAL * 0dB=0.775Vrms
 - Speaker Type2 Way Fashion Spekaer
 - ColorBlack / White
 - Rated Input Power20W
 - Max Input power50W
 - Woofer Type120mm(5"inch) free-edge type speaker
 - Tweeter Type61mm(2 1/4"inch) cone type speaker
 - Matching Transformer Impedance500ohm
 - S.P.L(1m/1W)90dB±2dB
 - Frequency Response90Hz-18kHz
 - Resonance FrequencyWoofer : 65Hz
Tweeter : 1.2kHz
 - Nominal impedanceWoofer : 6ohm(300Hz)
Tweeter : 6ohm(2.5kHz)
 - Connector TerminalPush Terminal 4P
- GENERAL
 - Weight3.1kg/6.8lb
 - Dimensions160(W) x 250(H) x 170(D)mm
6.3(W) x 10(H) x 6.7(D)in

GS-50BT/50WT

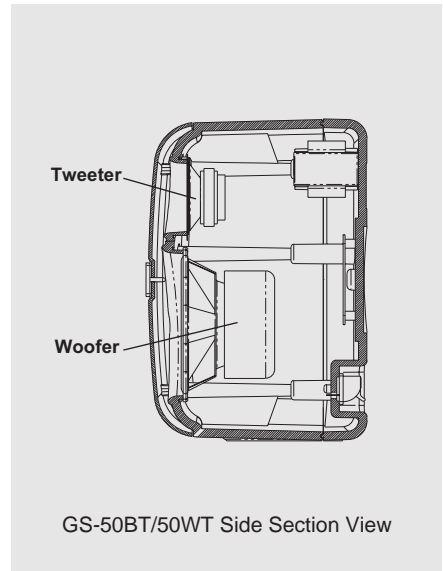
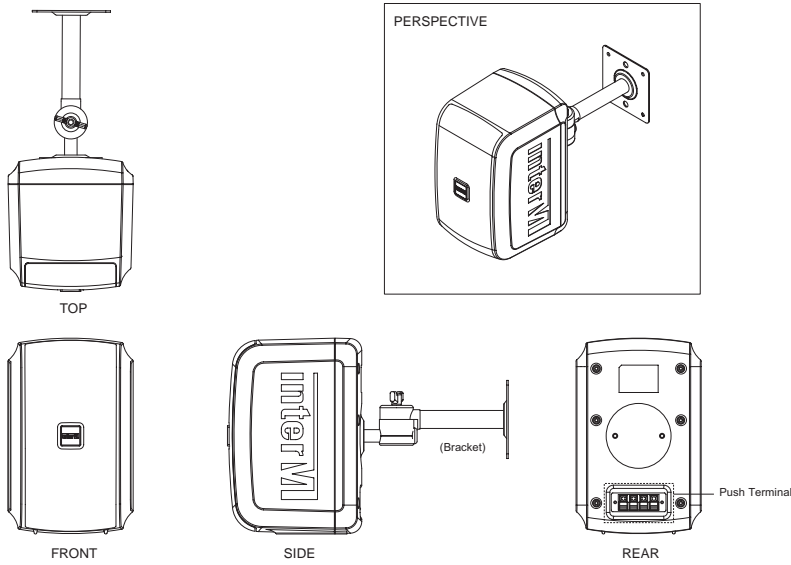

POLAR PATTERN DIAGRAM

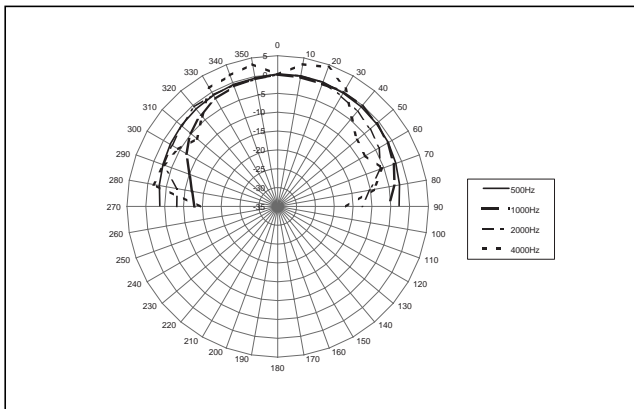

MATCHING TRANSFORMER

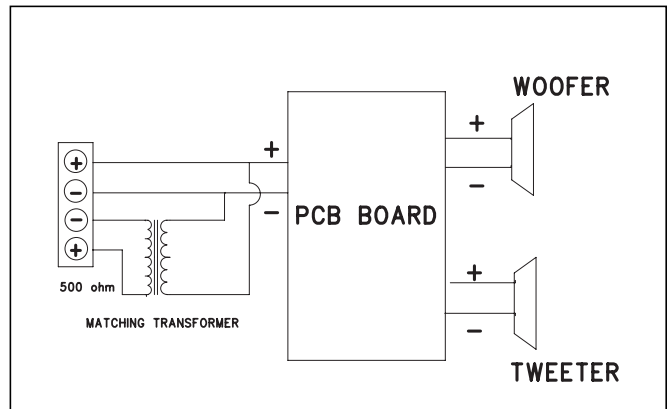

FREQUENCY RESPONSE

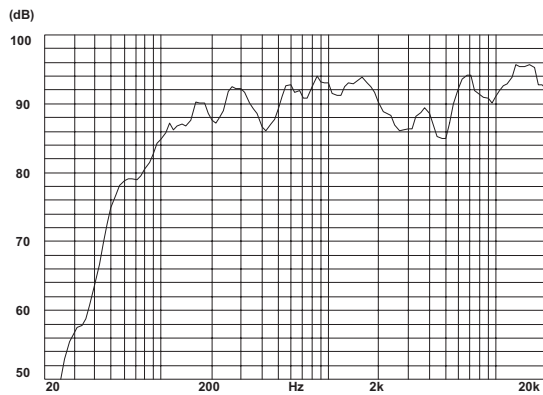

IMPEDANCE

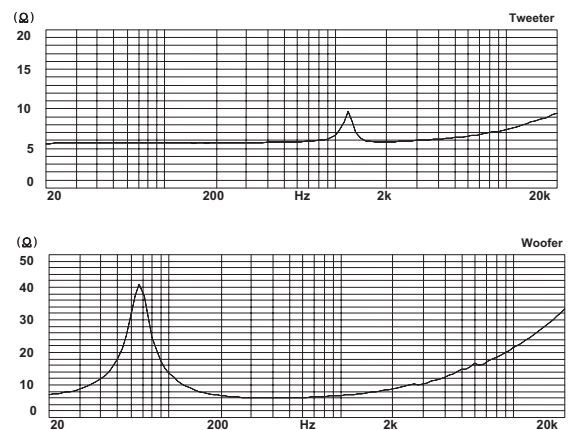

interM

OFFICE : 653-5 BANGHAK-DONG, DOBONG-KU, SEOUL, KOREA TEL : 82-2-2289-8140~8, FAX : 82-2-2289-8149
 Home page : <http://www.inter-m.com> E-mail : export@inter-m.com

9027011410