

SERVICE

MANUAL

S T E R E O P O W E R E D

MIXER

SFX-8445/8460

interM

SPECIFICATIONS

0dB=0.775Vrms,0dBV-1Vrms

- ELECTRICAL

	SFX-8445	SFX-8460
Maximum Output Level	450W+450W/2Ω@1% THD at 1kHz 300W+300W/4Ω@0.5% THD at 1kHz 200W+200W/8Ω@0.5% THD at 1kHz	600 W+600W/2Ω@0.5% THD at 1kHz 450W+450W/4Ω@0.5% THD at 1kHz 300W+300W/8Ω@0.5% THD at 1kHz
Frequency Response	20Hz~20kHz+1dB, -3dB @1W output into 8Ω(AMP OUT) 20Hz~20kHz+1dB, -3dB @+4dB output into 10kΩ(MAIN OUT, MONITOR OUT)	
Total Harmonic Distortion	Less than 0.5%@1kHz, 1/2 Power output into 4Ω(SPEAKERS OUT) Less than 0.1%@20Hz-20kHz, +14dB output into 10kΩ (MAIN OUT, MONITOR OUT, EFFECT OUT)	
Hum and Noise (Average, Rs-150&) (with 20Hz-20kHz BPF)	-127dB equivalent input noise -95dB residual output noise (MAIN OUT, MONITOR OUT, EFX OUT) -75dB MAIN OUT, EFX OUT Master level control at maximum all channel level control at minimum -75dB MONITOR OUT Master level control at maximum all channel level control at minimum	
Maximum Voltage Gain	66dB CH IN (MIC) to MAIN OUT, MONITOR OUT 72dB CH IN (MIC) to EFX OUT 48dB CH IN (MIC) to REC OUT 46dB CH IN (LINE) to MAIN OUT, MONITOR OUT 36dB CH IN (ST LINE) to MAIN OUT, MONITOR OUT 12dB AUX IN to MAIN OUT 26dB TAPE IN to MAIN OUT	
Interference(Crosstalk) at 1kHz	70dB adjacent input, 70dB input to output	
Input Channel EQ	HIGH 12kHz shelving (±12dB Maximum) MID 2.5kHz peaking (±12dB Maximum) LOW 80Hz shelving (±12dB Maximum) * Turn over/roll-off frequency of shelving: 3dB below maximum variable level	
Level Meter	10 Points LED Meter (MAIN OUT L/R, MONITOR OUT)	
Graphic Equalizer	9 bands (63, 125, 250, 500, 1k, 2k, 4k, 8k, 16kHz) ±12dB Maximum (MAIN OUT, MONITOR OUT)	
Internal Digital Effect	16 programs	
Phantom Power	+48V	
Clip Indicators	Turn on: THD ≥ 0.1%	
Foot Switch	Digital Effect Mute: on/off	

- GENERAL

Power Source	AC 100-120VAC or AC 220-240VAC, 50/60Hz (supplied ac mains transformer depends on country requirements)	
Power Consumption	350W (1/8 power)	450W (1/8 power)
Weight	21kg/46.3lb	23kg/50.7lb
Dimension	518(W)x324(H)x324(D)mm/20.4(W)x12.7(H)x12.7(D)in	

* Specifications and design subject to change without notice.

BLOCK DIAGRAM

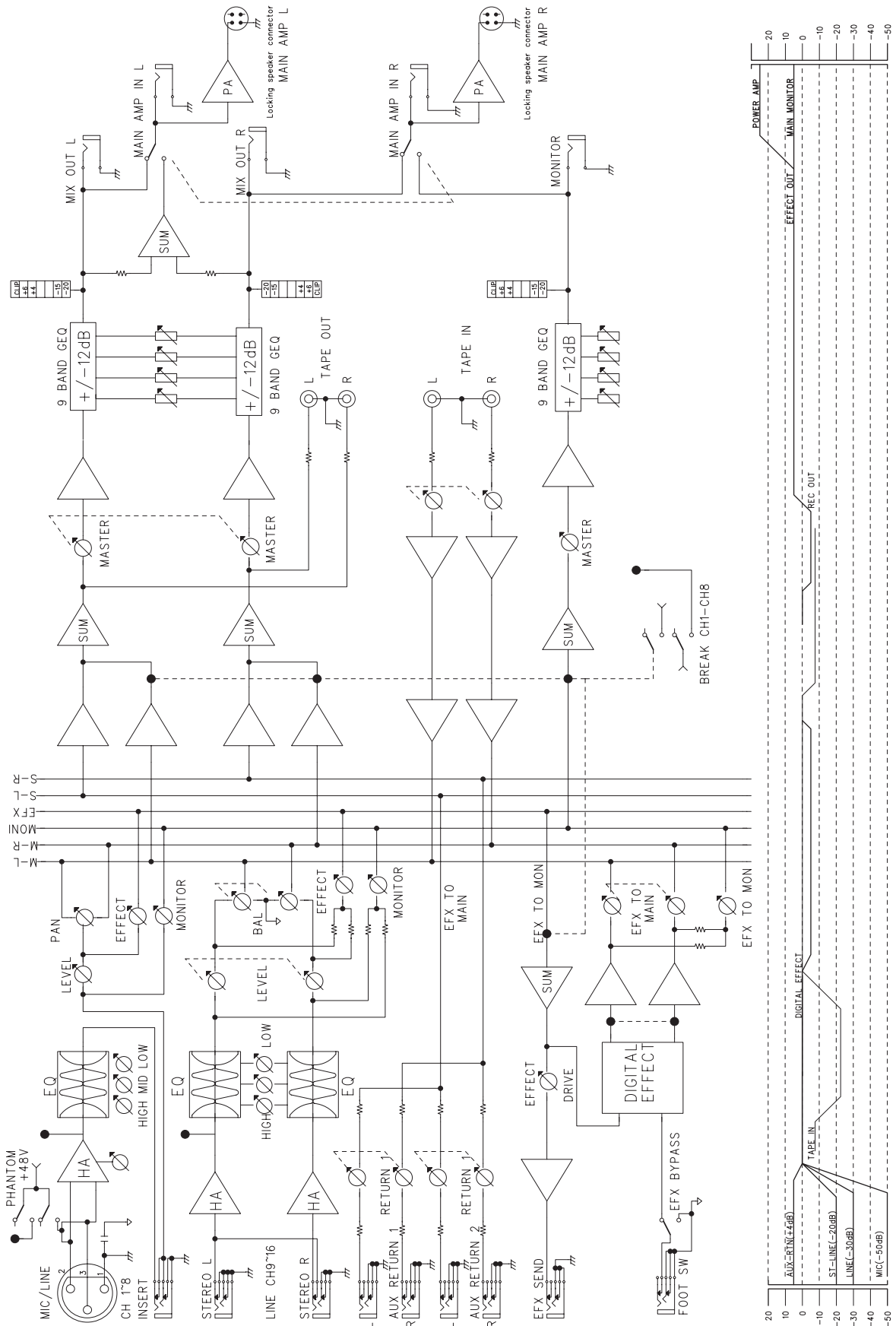

ELECTRICAL PARTLIST

Ref No.	Part No.	Description	Value	Ref No.	Part No.	Description	Value
AMP B'D (4003475500)				R236			
Q103-104 Q122	2008005999	TR PNP 2SA 1546 NEC	2SA 1546	R175 R177-178	3009222973	RES CF 2.2K 1/5W J N	2.2K
Q203-204 Q222	2008206104-T	KTA1268-BL-AT	KTA1268BL	R180 R275			
Q112 Q115 Q117	2008206106-T	KTA2400-GR-AT	KTA 2400G	R277-278 R280			
Q212 Q215 Q217				R78 R96	3009223973	RES CF 22K 1/5W J N	22K
Q108 Q110 Q208	2008207100-T	TR PNP 2SA 970BL-TPE2	2SA970BL	R184-185 R194			
Q210				R294			
Q119 Q219	2008405999	TR NPN 2SC4001 NEC	2SC 4001	R169-172	3009332973	RES CF 3.3K 1/5W J N	3.3K
Q101-102 Q107	2008606108-T	KTC3200-BL-AT	C3200BL	R269-272			
Q111 Q137				R109	3009333973	RES CF 33K 1/5W J N	33K
Q201-202 Q207				R111 R115 R211	3009470973	RES CF 47 1/5W J N	47
Q211 Q237				R215			
Q113-114 Q116	2008606117-T	KTC3400-GR-AT	KTC 3400G	R114 R118 R214	3009472973	RES CF 4.7K 1/5W J N	4.7K
Q213-214 Q216				R218			
Q121 Q221	2008606999-T	KTC3198-BL-AT	KTC 3198BL	R141-142 R189	3009473973	RES CF 47K 1/5W J N	47K
Q126 Q128 Q130	2028107118	TR PW PNP 15A 230V 2SA1943	2SA 1943	R241-242 R289			
Q132 Q226 Q228				R138 R176 R179	3009561973	RES CF 560 1/5W J N	560
Q230 Q232				R238 R276 R279			
Q124 Q224	2028107984	KTA1659A-Y-U	KTA1659A	R195-198	3009562973	RES CF 5.6K 1/5W J N	5.6K
Q125 Q127 Q129	2028407122	TR NPN 2SC5200 TOSHIBA	2SC5200	R295-298			
Q131 Q225 Q227				R102-103	3009563973	RES CF 56K 1/5W J N	56K
Q229 Q231				R202-203			
Q105 Q120 Q123	2028407990	KTC4370A-Y-U	KTC4370A	R174 R182 R190	3009682973	RES CF 6.8K 1/5W J N	6.8K
Q220 Q223				R274 R282 R290			
Q134 Q136 Q234	2038206805	KTA1275-Y-AT	A1275Y	R119-120	3009683973	RES CF 68K 1/5W J N	68K
Q236				R219-220			
Q133 Q135 Q233	2038606705	KTC3228-Y-AT	2SC3228	R173 R181	3009822973	RES CF 8.2K 1/5W J N	8.2K
Q235				R191-192 R273			
Q109 Q209	2048000989	FET IRFP150N N-CH IR	IRFP 150N	R281 R291-292			
Q106 Q206	2048000993	FET IRFP9140N P-CH IR	IRFP 9140N	R100 R303	3039100674-F	RES MO 10 3W J P	10 3W
D115-116	2058100110	DIODE RL207 PYUNG CHANG	RL207	R108	3039103472-T	RES MO 10K 1W J T	10K 1W
D215-216				R3	3039220575-T	RES MO 22 2W J RADIAL	22 2W
D103-104	2058100975	DIODE FML-G12S SANKEN	FML-G12S	R199-200	3039332472-F	RES MO 3.3K 1W J	3.3K 1W
D203-204				R299-300			
D119 D219	2058100996	DIODE RECTIFIER LT1N4006(4007)	1N 4006	R1-2 R183 R283	3039479575-T	RES MO 4.7 2W J RADIAL	4.7 2W
D105-114	2058304100	DIODE IN4148M	1N 4148	R301-302			
D117-118				R144 R244	3039680575-T	RES MO 68 2W J RADIAL	68 2W
D205-214				R4 R26 R147-148	3059478773-A	RES CE 0.47 5W J AXIAL	0.47 5W
D217-218				R153-154			
D101-102	2058502240	DIODE ZENER UZ-24BM(1N5252B)	UZ 24BM	R159-160			
IC101-102	2118050410	IC TA7317P TOSHIBA	TA 7317P	R165-166			
TH101 TH201	2438007993	POSISTOR PTFM04BE222Q2N34B0	BE222TS	R247-248			
L101 L201	2648099940	COIL INDUCTOR 1.2UH	1.2uH	R253-254			
R132 R232	3002110953	RES CF 11K 1/5W FN	11K 1%	R259-260			
R131 R231	3004620953	RES CF 620 1/5W F N	620 1%	R146 R149 R152	3089101275	RES NFR 100 1/4W J R PHILKO	FR 100
R139 R239	3009000973	RES CF 0 1/5W JN	0	R155 R158 R161			
R101 R124-125	3009101973	RES CF 100 1/5W J N	100	R164 R167 R246			
R128-129 R201				R249 R252 R255			
R224-225				R258 R261 R265			
R228-229				R267			
R107 R112-113	3009102973	RES CF 1K 1/5W J N	1K	R140 R143 R240	3089470275	RES NFR 47 1/4W JR PHILKO	FR 47
R116-117 R123				R243			
R126-127 R130				R145 R150-151	3089479275	RES NFR 4.7 1/4W J R PHILKO	FR 4.7
R207 R212-213				R156-157			
R216-217 R223				R162-163 R168			
R226-227 R230				R245 R250-251			
R105-106	3009104973	RES CF 100K 1/5W J N	100K	R256-257			
R187-188 R193				R262-263 R268			
R205-206				VR101 VR201	3248347120-T	RES SEMI RH063MCS2R	470B
R287-288 R293				C127 C227	3409210059-T	CAP RG 10UF 50V 105C	10/50
R110	3009123973	RES CF 12K 1/5W J N	12K	C105 C107 C109	3409210091	CAP AF SG 10UF 100V	10/100
R121-122	3009151973	RES CF 150 1/5W J N	150	C112-113 C207			
R221-222				C209 C213 C262			
R137 R237	3009152973	RES CF 1.5K 1/5W J N	1.5K	C104	3409210181	CAP AF SG 100UF 63V	100/63
R186 R286	3009184973	RES CF 180K 1/5W J N	180K	C115 C215	3409222141-T	CAP AF RSG 220UF 25V J 8 P	220/25
R133 R136 R233	3009221973	RES CF 220 1/5W J N	220	C102 C202	3409247041-T	CAP AF RSG 47UF 25V 5 P	47/25
				C122 C222	3409247071-T	CAP AF RSG 47UF 50V 6 P	47/50
				C123 C223	3409810141-T	CAP AF NP 100UF 25V	100/25 NP

Ref No.	Part No.	Description	Value
C124-125	3509150130-T	CAP CE SL 15PF 50V J	15P
C224-225			
C114 C214	3509220130-T	CAP CE SL 22PF 50V J	22P
C101 C201	3509222530-T	CAP CE B 0.0022UF 50V K	0.0022/50
C103 C203	3609104120-T	CAP MA 0.1UF 100V J	0.1/100(M)
C126 C226	3609104140-T	CAP MA 0.1UF 200V J	0.1/200(M)
C118-119	3609473120-T	CAP MA 0.047UF 100V	0.047/100(M)
C218-219			
C116-117	3619101210	CAP PL 100PF 100V J	100P/100
C216-217			
C106 C108 C206	3619223263	CAP POLYFILM 0.022UF 400V	0.022/400
C208			
C120-121	3619331210	CAP PL 330PF 100V J	330P/100
C220-221			
CN103 CN203	4355923802	WAFER B-2P JST	WAFER B-2P JST
CN104 CN204	4355923805	WAFER LW(3.96) 5P JIS	WAFER 5P JIS
CN101 CN201	4428595012	LW5267/LWB0640/2.5MM-12P	CON WAFER 12P
CN102	4428595014	LW5267/LWB0640/2.5MM-14P	CON WAFER 14P
F101A F101B	4458999110	FUSE CLIP 5*20	FUSE CLIP 5*20
F101	5508212730	FUSE 217F 20MM 2A/250V UCSKJ	T2AL/250V
RY101 RY201	5528007700	RELAY AZ971-1A DC24V	AZ971-1A
H101-102	7505299340	HEAT SINK EQ-131	HEAT SINK
H201-202			

MIXER B'D (C4003475400)

Q101-102	2008207100-T	2008207100-T	2SA 970BL
Q201-202			
Q301-302			
Q401-402			
Q501-502			
Q601-602			
Q701-702			
Q801-802			
Q1401 Q1501	2008606998-T	KTD1302-AT	D1302
Q1701 Q1801			
Q901 Q1001	2008613000-T	TR NPN 2SD1111 (SANYO,NEC)	2SD1111
Q1101 Q1201			
D101-105	2058304100	DIODE IN4148M	1N 4148
D201-205			
D301-305			
D401-405			
D501-505			
D601-605			
D701-705			
D801-805			
D901-902			
D1001-1002			
D1101-1102			
D1201-1202			
U101-104	2118010432	IC NJM2068DD JRC	NJM 2068DD
U301-304			
U501-504			
U701-704 U1401			
U1406-1414			
U1703-1707			
U1415 U1501	2118030405	KIA6966S	6966
U1709			
U1416 U1502	2118040105	KIA6967S	6967
U1708			
U901-902	2168220989	IC NJM 2068L JRC	NJM 2068L
U1001-1002			
U1101-1102			
U1201-1202			
U1301			
U1402-1405			
U1417			
U1701-1702			
U1801-1802			

Ref No.	Part No.	Description	Value
L105 L201 L301	2300030100	LED LTL-1CHE LITEON	RED
L401 L501 L560			
L601 L701 L801			
L901 L1001			
L1101 L1201			
L1410 L1510			
L1712-1716			
L557-559	2300031100	LED LTL-1CHY LITEON	YEL
L1407-1409			
L1507-1509			
L551-556	2300032100	LED LTL-1CHG LITEON	GRN
L1401-1406			
L1501-1506			
L1711 L1717			
R107-108	3002150953	RES CF 15K 1/5W F N	15K 1%
R207-208			
R307-308			
R407-408			
R507-508			
R607-608			
R707-708			
R807-808			
R903-904	3003180953	RES CF 1.8K 1/5W F N	1.8K 1%
R1003-1004			
R1103-1104			
R1203-1204			
R113 R115 R213	3003220953	RES CF 2.2K 1/5W F N	2.2K 1%
R215 R313 R315			
R413 R415 R513			
R515 R613 R615			
R713 R715 R813			
R815			
R104 R106 R204	3003560953	RES CF 5.6K 1/5W F N	5.6K 1%
R206 R304 R306			
R404 R406 R504			
R506 R604 R606			
R704 R706 R804			
R806			
R101-102 R109	3003680953	RES CF 6.8K 1/5W F N	6.8K 1%
R112 R114			
R201-202 R209			
R212 R214			
R301-302 R309			
R312 R314			
R401-402 R409			
R412 R414			
R501-502 R509			
R512 R514			
R601-602 R609			
R612 R614			
R701-702 R709			
R712 R714			
R801-802 R809			
R812 R814			
R117-118	3003909953	RES CF 9.09K 1/5W F N	9.09K 1%
R217-218			
R317-318			
R417-418			
R517-518			
R617-618			
R717-718			
R817-818			
R110-111	3005100953	RES CF 10 1/5W F N	10 1%
R210-211			
R310-311			
R410-411			
R510-511			
R610-611			

Ref No.	Part No.	Description	Value
R710-711			
R810-811			
R120 R220 R320	3009100973	RES CF 10 1/5W J N	10
R420 R520 R620			
R720 R820			
R121 R221 R321	3009101973	RES CF 100 1/5W J N	100
R421 R521 R621			
R721 R821			
R901-902			
R1001-1002			
R1101-1102			
R1201-1202			
R1301-1302			
R1305-1306			
R1313-1314			
R1317-1318			
R1-3	3009102973	RES CF 1K 1/5W J N	1K
R1321-1322			
R1436			
R37-38	3009103973	RES CF 10K 1/5W J N	10K
R126-127 R137			
R139 R226-227			
R237 R239			
R326-327 R337			
R339 R426-427			
R437 R439			
R526-527 R537			
R539 R626-627			
R637 R639			
R726-727 R737			
R739 R826-827			
R837 R839			
R915-920			
R1015-1020			
R1115-1120			
R1215-1220			
R1404-1406			
R1437-1439			
R1504-1505			
R1507			
R1702-1704			
R1802-1803			
R1805 R1809			
R103 R119 R131	3009104973	RES CF 100K 1/5W J N	100K
R203 R219 R231			
R303 R319 R331			
R403 R419 R431			
R503 R519 R531			
R603 R619 R631			
R703 R719 R731			
R803 R819 R831			
R1408 R1411			
R1443 R1445			
R1508 R1511			
R1537 R1539			
R1708 R1733			
R1735 R1807			
R1417 R1542	3009122973	RES CF 1.2K 1/5W J N	1.2K
R124 R224 R324	3009123973	RES CF 12K 1/5W J N	12K
R424 R524 R624			
R724 R824			
R923 R1023	3009124973	RES CF 120K 1/5W J N	120K
R1123 R1223			
R1416 R1541	3009152973	RES CF 1.5K 1/5W J N	1.5K
R1740-1743			
R924 R1024	3009182973	RES CF 1.8K 1/5W J N	1.8K
R1124 R1224			
R1738			

Ref No.	Part No.	Description	Value
R132-134 R138	3009183973	RES CF 18K 1/5W J N	18K
R140-141			
R232-234 R238			
R240-241			
R332-334 R338			
R340-341			
R432-434 R438			
R440-441			
R532-534 R538			
R540-541			
R632-634 R638			
R640-641			
R732-734 R738			
R740-741			
R832-834 R838			
R840-841			
R907-908			
R1007-1008			
R1107-1108			
R1207-1208			
R1706			
R921 R1021	3009202973	RES CF 2K 1/5W J N	2K
R1121 R1221			
R1402 R1407	3009203973	RES CF 20K 1/5W J N	20K
R1440 R1502			
R1506 R1534			
R1705 R1739			
R1806			
R116 R216 R316	3009220973	RES CF 22 1/5W J N	22
R416 R516 R616			
R716 R816			
R911-912	3009222973	RES CF 2.2K 1/5W J N	2.2K
R1011-1012			
R1111-1112			
R1211-1212			
R1409 R1509			
R1412-1413	3009272973	RES CF 2.7K 1/5W J N	2.7K
R1512-1513			
R1709-1710			
R125 R225 R325	3009303973	RES CF 30K 1/5W J N	30K
R425 R525 R625			
R725 R825			
R129-130	3009333973	RES CF 33K 1/5W J N	33K
R229-230			
R329-330			
R429-430			
R529-530			
R629-630			
R729-730			
R829-830			
R39 R135 R235	3009363973	RES CF 36K 1/5W J N	36K
R335 R435 R535			
R635 R735 R835			
R909-910			
R1009-1010			
R1109-1110			
R1209-1210			
R1309-1312			
R1403 R1503			
R1701 R1801			
R905-906	3009391973	RES CF 390 1/5W J N	390
R1005-1006			
R1105-1106			
R1205-1206			
R136 R236 R336	3009392973	RES CF 3.9K 1/5W J N	3.9K
R436 R536 R636			
R736 R836			
R1323-1324			

Ref No.	Part No.	Description	Value
R913-914	3009433973	RES CF 43K 1/5W JN	43K
R1013-1014			
R1113-1114			
R1213-1214			
R1442 R1536			
R1732			
R122 R222 R322	3009472973	RES CF 4.7K 1/5W J N	4.7K
R422 R522 R622			
R722 R822			
R1410 R1441			
R1510 R1535			
R1731 R1808			
R35-36	3009473973	RES CF 47K 1/5W J N	47K
R1315-1316			
R1319-1320			
R1325-1326			
R1401 R1414			
R1501 R1514			
R1711 R1810			
R1419 R1421	3009561973	RES CF 560 1/5W J N	560
R1423 R1425			
R1427-1428			
R1430 R1432			
R1435 R1516			
R1518 R1520			
R1522 R1524			
R1526 R1528			
R1530 R1532			
R1714-1715			
R1718-1719			
R1721 R1723			
R1725 R1727			
R1729			
R1418 R1420	3009563973	RES CF 56K 1/5W J N	56K
R1422 R1424			
R1426 R1429			
R1431			
R1433-1434			
R1444 R1517			
R1519 R1521			
R1523 R1525			
R1527 R1529			
R1531 R1533			
R1538 R1707			
R1713			
R1716-1717			
R1720 R1722			
R1724 R1726			
R1728 R1730			
R1736			
R123 R223 R323	3009683973	RES CF 68K 1/5W J N	68K
R423 R523 R623			
R723 R823			
R1415 R1515	3009750973	RES CF 75 1/5W JN	75
R1712 R1811			
R128 R228 R328	3009822973	RES CF 8.2K 1/5W J N	8.2K
R428 R528 R628			
R728 R828			
R922 R1022	3009824973	RES CF 820K 1/5W J N	820K
R1122 R1222			
R1744	3039103472-F	RES MO 10K 1W	10K 1W
R1540 R1737	3039181472-F	RES MO 180 1W J	180 1W
R1745-1746	3039681472-F	RES MO 680 1W J	680 1W
R105 R205 R305	3089101275	RES NFR 100 1/4W J R PHILKO	FR 100
R405 R505 R605			
R705 R805			
VR901 VR1001	3228067410	VR XV012313YGPV30F 10A(D)20K	20KD*2
VR1101 VR1201			

Ref No.	Part No.	Description	Value
VR105-107	3228068910	VR RK09S114000423A	20KA
VR205-207			
VR305-307			
VR405-407			
VR505-507			
VR605-607			
VR705-707			
VR805-807			
VR903-904			
VR1003-1004			
VR1103-1104			
VR1203-1204			
VR1701 VR1711			
VR1801			
VR101 VR201	3228068920	VR RK09S114000423G	20KRD
VR301 VR401			
VR501 VR601			
VR701 VR801			
VR902 VR1002	3228069020	VR RK12U124000423A	20KA*2
VR1102 VR1202			
VR1301-1303			
VR1401-1402			
VR1702-1710	3238080010	RS20H123D12B23W	20KW
VR351-359			
VR102-104	3238093010	VR RK09K113000553A	50KB
VR108			
VR202-204			
VR208			
VR302-304			
VR308			
VR402-404			
VR408			
VR502-504			
VR508			
VR602-604			
VR608			
VR702-704			
VR708			
VR802-804			
VR808 VR905			
VR1005 VR1105			
VR1205			
C1401 C1404	3409210141-T	CAP AF RSG 100UF 25V 6 P	100/25
C1423 C1501			
C1507 C1520			
C1543 C1701			
C1715 C1747			
C1758-1761			
C1814			
C126 C326 C526	3409210171-T	CAP AF RSG 100UF 50V 8 P	100/50
C726			
C110 C210 C310	3409210221-T	CAP AF RSG 1000UF 6.3V 10 P	1000/6.3
C410 C510 C610			
C710 C810			
C1427 C1522	3409210971-T	CAP AF RSG 1UF 50V 5 P	1/50
C1717			
C102 C105 C202	3409222081-T	CAP AF RSG 22UF 63V 6 P	22/63
C205 C302 C305			
C402 C405 C502			
C505 C602 C605			
C702 C705 C802			
C805			
C125 C225 C325	3409233971-T	CAP AF RSG 3.3UF 50V 5 P	3.3/50
C425 C525 C625			
C725 C825			
C106-107	3409247041-T	CAP AF RSG 47UF 25V 5 P	47/25
C113-114			
C121-122 C127			

Ref No.	Part No.	Description	Value	Ref No.	Part No.	Description	Value
C206-207				C1203-1204			
C213-214				C1301-1302			
C221-222 C227				C1305-1306			
C306-307				C1309-1310			
C313-314				C1424 C1426			
C321-322 C327				C1463 C1466			
C406-407				C1521 C1545			
C413-414				C1716 C1809			
C421-422 C427				C1815			
C506-507				C103-104	3509102530-T	CAP CE B 0.001UF 50V J	0.001/50
C513-514				C203-204			
C521-522 C527				C303-304			
C606-607				C403-404			
C613-614				C503-504			
C621-622 C627				C603-604			
C706-707				C703-704			
C713-714				C803-804			
C721-722 C727				C124 C128-129	3509103530-T	CAP CE F 0.01UF 50V Z	0.01/50
C806-807				C137-138 C224			
C813-814				C324 C328-329			
C821-822 C827				C332-333 C424			
C901-902 C909				C524 C528-529			
C911-913				C536-537 C624			
C916-917				C724 C728-729			
C1001-1002				C737-738 C824			
C1009				C910 C1010			
C1011-1013				C1110 C1210			
C1016-1017				C1407-1408			
C1101-1102				C1412-1413			
C1109				C1416			
C1111-1113				C1445-1460			
C1116-1117				C1515 C1709			
C1201-1202				C1748-1751			
C1209				C1754-1757			
C1211-1213				C1806-1807			
C1216-1217				C1812			
C1303-1304				C1-4	3509104530-T	CAP CE F 0.1UF 50V Z	0.1/50
C1307-1308				C111-112	3509151130-T	CAP CE SL 150PF 50V J	150P
C1311-1312				C211-212			
C1315-1316				C311-312			
C1403				C411-412			
C1409-1410				C511-512			
C1414-1415				C611-612			
C1421 C1425				C711-712			
C1462 C1506				C811-812			
C1510				C123 C223 C323	3509220130-T	CAP CE SL 22PF 50V J	22P
C1512-1514				C423 C523 C623			
C1518 C1544				C723 C823			
C1704-1705				C914-915			
C1707-1708				C1014-1015			
C1711 C1801				C1114-1115			
C1804-1805				C1214-1215			
C1810-1811				C1405 C1508	3509221130-T	CAP CE SL 220PF 50V J	220P
C101 C201 C301	3409247081-T	CAP AF SG 47UF 63V 8 P	47/63	C1702 C1802			
C401 C501 C601				C1813	3509330130-T	CAP CE SL 33PF 50V J	33P
C701 C801				C1417 C1516	3509331130-T	CAP CE SL 330PF 50V J	330P
C1467-1469	3409247972-T	CAP AF RSS 4.7UF 50V 5 P	4.7/50	C905-906	3509470130-T	CAP CE SL 47PF 50V J	47P
C1540-1542				C1005-1006			
C1744-1746				C1105-1106			
C116 C216 C316	3509100130-T	CAP CE SL 10PF 50V D	10P	C1205-1206			
C416 C516 C616				C1411 C1418			
C716 C816				C1511 C1517			
C1132				C1703 C1706			
C1313-1314				C1710			
C1803				C108-109	3509471130-T	CAP CE SL 470PF 50V J	470P
C903-904	3509101130-T	CAP CE SL 100PF 50V J	100P	C208-209			
C1003-1004				C308-309			
C1103-1104				C408-409			

Ref No.	Part No.	Description	Value
C508-509			
C608-609			
C708-709			
C808-809 C1422			
C1519 C1712			
C1402 C1503	3509680130-T	CAP CE SL 68PF 50V J	68P
C1444 C1539	3509681130-T	CAP CE B 680PF 50V K	680P
C1742			
C1406 C1509	3529100110-T	CAP CE RH 10PF 50V D	10P
C1430 C1525	3609104120-T	CAP MA 0.1UF 100V J	0.1/100(M)
C1720			
C1436 C1531	3609123120-T	CAP MA 0.012UF 100V J	0.012(M)
C1735			
C115 C215 C315	3609152120-T	CAP MA 0.0015UF 100V J	0.0015(M)
C415 C515 C615			
C715 C815			
C1442 C1537			
C1741			
C1433 C1528	3609154122-T	CAP MA 0.15UF 100V MINI	0.15(M)
C1732			
C1439 C1534	3609183120-T	CAP MA 0.018UF 100V	0.018(M)
C1738			
C1434 C1529	3609223120-T	CAP MA 0.022UF 100V J	0.022(M)
C1733			
C1440 C1535	3609272120-T	CAP MA 0.0027UF 100V J	0.0027(M)
C1739			
C117 C217 C317	3609332120-T	CAP MA 0.0033UF 100V	0.0033/100
C417 C517 C617			
C717 C817			
C1437 C1532	3609333120-T	CAP MA 0.033UF 100V J	0.033(M)
C1736			
C1443 C1538	3609472120-T	CAP MA 0.0047UF 100V J	0.0047(M)
C1743			
C119-120	3609473120-T	CAP MA 0.047UF 100V	0.047(M)
C219-220			
C319-320			
C419-420			
C519-520			
C619-620			
C719-720			
C819-820 C918			
C1018 C1118			
C1218 C1432			
C1527 C1731			
C118 C218 C318	3609562120-T	CAP MA 0.0056UF 100V	0.0056(M)
C418 C518 C618			
C718 C818			
C1438 C1533			
C1737			
C1435 C1530	3609683120-T	CAP MA 0.068UF 100V J	0.068(M)
C1734			
C1441 C1536	3609822120-T	CAP MA 0.0082UF 100V	0.0082(M)
C1740			
C1428 C1523	3639184111-T	CAP ECQ-V 1H184JL2 0.18UF 50V	0.18/50
C1718			
C1431 C1526	3639274111-T	CAP ECQ-V 1H274JL2 0.27UF 50V	0.27/50
C1730			
C1429 C1524	3639564111-T	CAP ECQ-V 1H564JL2 0.56UF 50V	0.56/50
C1719			
J1	4355465303	CON ASS'Y 15P 100MM	15P CON
GND1	4355465415	CON ASS'Y 1P 330MM	con ass'y 1p
CN1701	4428595014	LW5267/LWB0640/2.5MM-14P	LW5267-14P
JK101 JK201	4438086300	JACK COMBO CXLF-06 NON-LOCK	CXLF-06L
JK301 JK401			
JK501 JK601			
JK701 JK801			
JK102 JK202	4438192910	PHONE JACK (5P) METAL	PHONE 5P
JK302 JK402			

Ref No.	Part No.	Description	Value
JK502 JK602			
JK702 JK802			
JK901-902			
JK1001-1002			
JK1101-1102			
JK1201-1202			
JK1301-1304			
JK1401-1402			
JK1501-1502			
JK1701			
JK1801-1802			
JK101B JK201B			
JK301B JK401B			
JK501B JK601B			
JK701B JK801B			
JK1305	4438194610	RCA JACK BOARD 4P(24MM)	RCA 4P
SW1701-1702	4628980110	SW PUSH JPS2281EAB JEIL	JPS2281
SW1802			
SW1401	4628991710	SW PUSH SPEC122SC011	SPEC 122
S1	4658098610	SW ENCODER SDB161PVB 15.5F	SW ENCODER
POWER B'D (C4003475600)			
HN2			WAFER 5P
HN1			WAFER 6P
Q1	2008606104-T	TR NPN KTC3198-Y-AT TO-92	KTC 3198Y
Q2-3	2008606998-T	KTD1302-AT	2SD 1302R
D3 D7	2058100500	DIODE BRIDGE GBPC-W 2504	GBPC-W 2504
D5-6	2058100976	DIODE BRIDGE KBP202G/KBP203G	KBPC 202G
D10-11	2058100996	DIODE RECTIFIER LT1N4006(4007)	1N 4006
D1-2	2058304100	DIODE IN4148M	1N 4148
U4 U7-8	2118010432	IC NJM2068DD JRC	NJM 2068DD
IC4	2118011305	KIA7805API-U	7805
IC2	2128610800	IC MC7915 COMMON	7915
IC1	2128610900	IC KA7815 COMMON	7815
R27	3009100973	RES CF 10 1/5W J N	10
R17 R26	3009102973	RES CF 1K 1/5W J N	1K
R5-6 R24-25	3009103973	RES CF 10K 1/5W J N	10K
R28-29 R31-36			
R18-21	3009113973	RES CF 11K 1/5W J N	11K
R3-4 R15-16	3009221973	RES CF 220 1/5W J N	220
R1-2 R7-10	3009222973	RES CF 2.2K 1/5W J N	2.2K
R13-14			
R30	3009471973	RES CF 470 1/5W J N	470
R11-12 R22-23	3009472973	RES CF 4.7K 1/5W J N	4.7K
C45-46	3408222261	CAP RSA 2200UF 35V SNAP 18 P	2200/35
C3-5 C7 C11	3409210071-T	CAP AF RSG 10UF 50V 5 P	10/50
C16 C23-24 C31			
C35 C37-39			
C52-56	3409222171-T	CAP AF RSG 220UF 50V SG 10 P	220/50
C47	3409233237	CAP AF SD 3300UF 16V	3300/16
C40-43	3419515376	CAP AF HE 15000UF 50V	15000/50
C48-51 C57-60	3509103530-T	CAP CE F 0.01UF 50V Z	0.01/50
C1-2 C8-9	3509104530-T	CAP CE F 0.1UF 50V Z	0.1/50
C12-15 C25-30			
C32-34 C36			
C61-62			
C17-18 C21-22	3509221130-T	CAP CE SL 220PF 50V J	220P
C19-20	3509471130-T	CAP CE SL 470PF 50V J	470P
C6 C10	3509472530-T	CAP CE F 0.0047UF 50V Z	0.0047/50
C44	3549472407	CAP DE2E3KH472MA4B	0.0047
C63-66	3609224153	CAP TL 0.22UF 250V(SAMWHA)	0.22/250(M)
X1	3938000965	X-TAL 12.288MHZ HC-49/U DOU	12.288MHz
AN101	4355734409	CON ASS'Y 12P 190MM	con ass'y 12p
AN102	4355734413	CON ASS'Y 12P 270MM	con ass'y 12p
CN2 CN104	4355923805	WAFER LW(3.96) 5P JIS	WAFER5P
CN204			
CN3	4355923806	CONNECTOR WAFER 06P(J.ST)	WAFER6P
JK1-2	4428299810	JACK SPEACON (PC-1635)	SPK

Ref No.	Part No.	Description	Value
CN1	4428594915	LA5268/LAB0640/2.5MM-15P	LA5267-15P
INLET	4448599010	AC INLET (B'D IN TYPE)	INLET
	4308991810	AC CORD DOM 10A INLET	DOM
	4308996710	AC CORD (WITHOUT PLUG)	C,D
	4308998000	AC CORD POWER FOR SAA	D
	4308997710	CORD AC(UL3 125V 13A)MODEL7000	E
	4308990810	AC POWER CORD JIS	J
	4308999410	AC CORD V+VII6A-250VHOVV-F3G	R
F1A F1B F2A F2B F3A F3B F4A F4B	4458999110	FUSE CLIP 5*20	CLIP
T1-9	4465998210	TERMINAL(250)PCB TAB	250TAB
S1	4648098610	SW PUSH PS3-22-P3AZ SOLTEAM	SW POWER
F1-2	5508412234	FUSE TSD 20MM 1A/250V U/C/S/V	T1AL/250V
F3-4	5508413536	FUSE TS 20MM 6.3A/250V U/C/S/V	T6.3AL
PT	C2828056000	TRANS POWER SFX-8445 COM	P.TRANSFORMER
U3	S2121316000	IC SCR AL3201 ALESIS DSP	AL3201_DSP
U5	S2125214540	IC MM74HC14M (SO14) FSC	74HC14M
U1	S2128116000	IC ADC AL1101 SOIC 16PIN	AL1101_ADC
U2	S2128216000	IC DAC AL1201 SOIC 16PIN	AL1201_DAC

SCHEMATIC DIGRAM

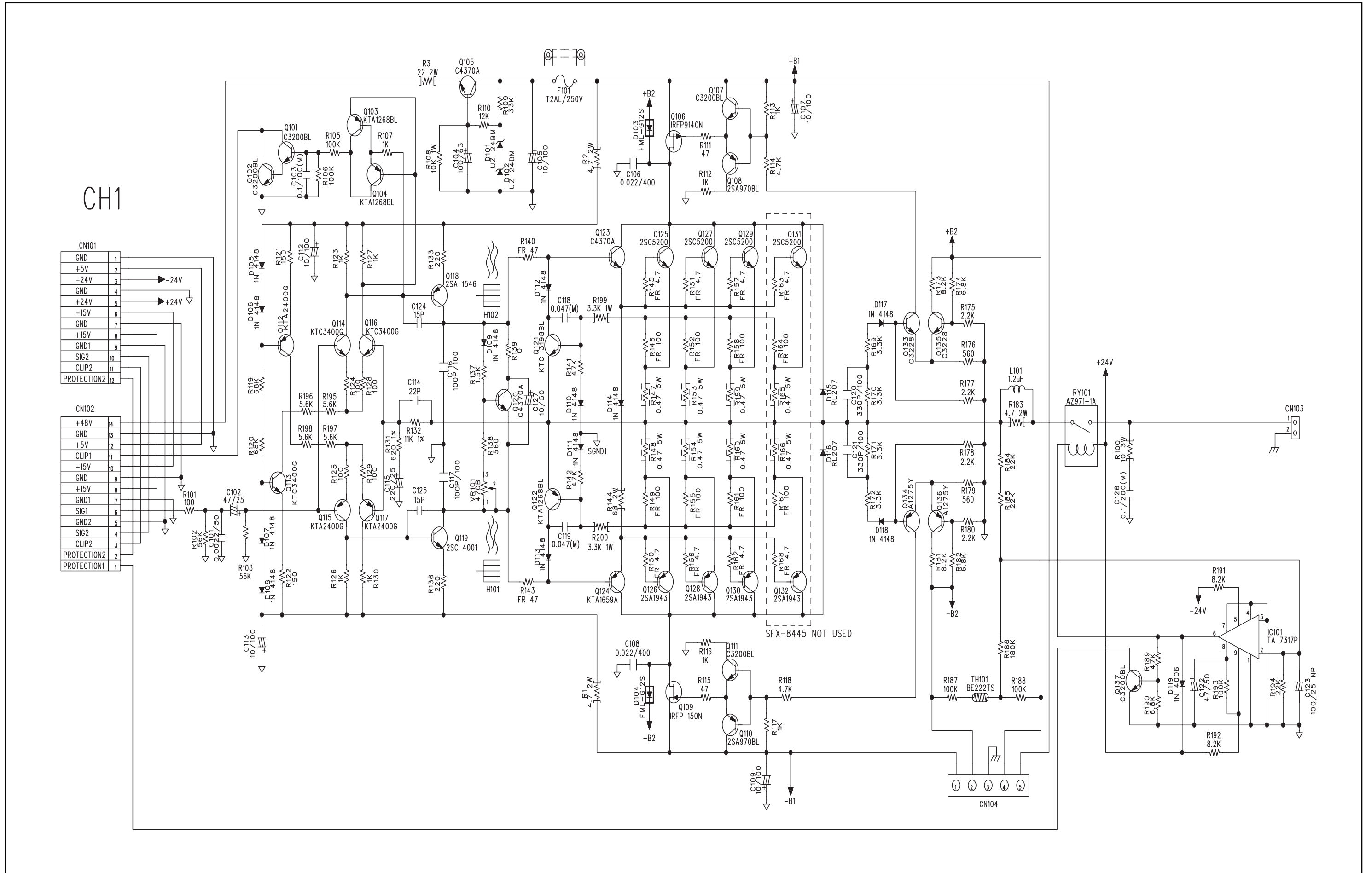

CH2

CN201	
PROTECTION2	12
CLIP2	11
SIG2	10
GND2	9
+15V	8
-15V	7
+24V	6
GND	5
-24V	4
NC	3
NC	2
NC	1

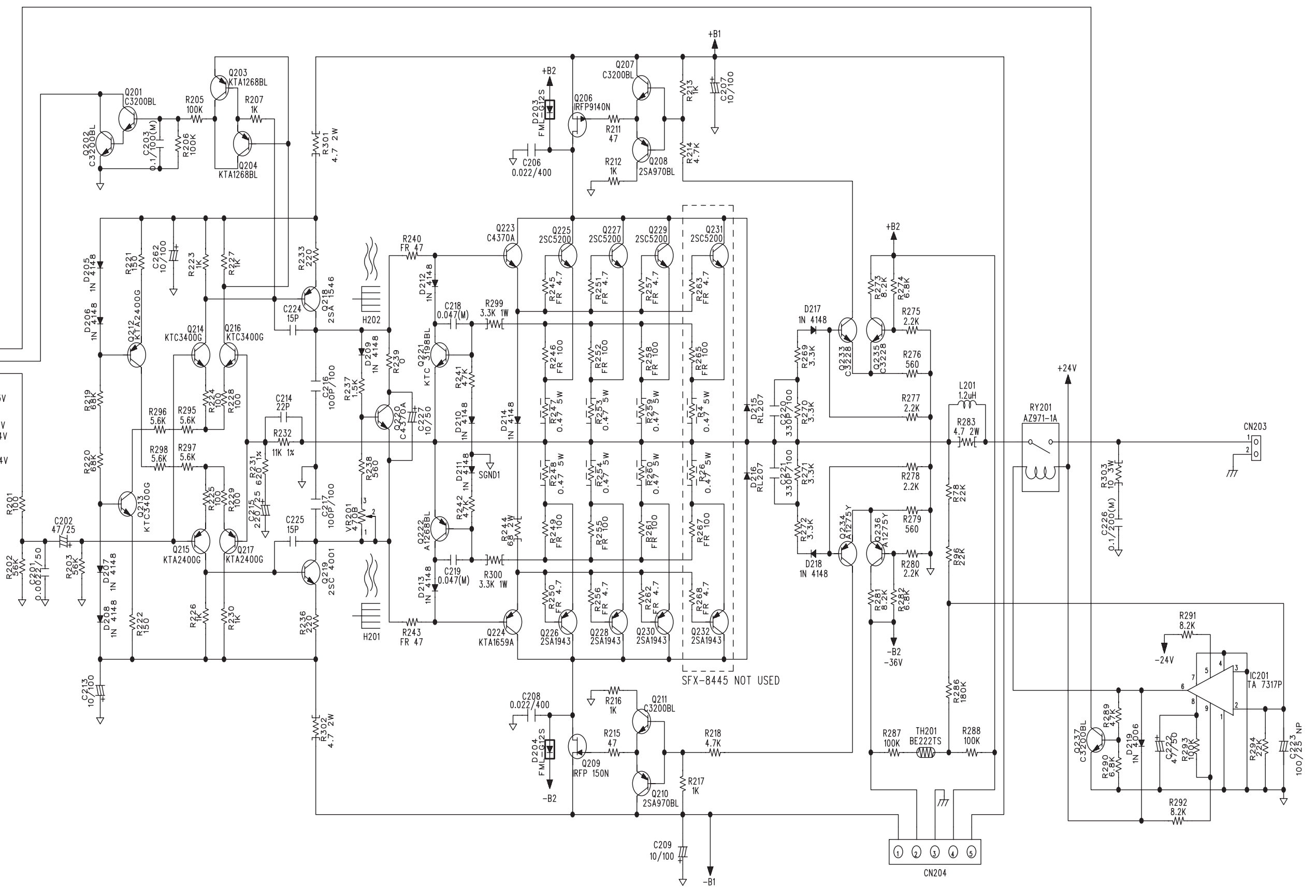

C4003475600
POWER B'D

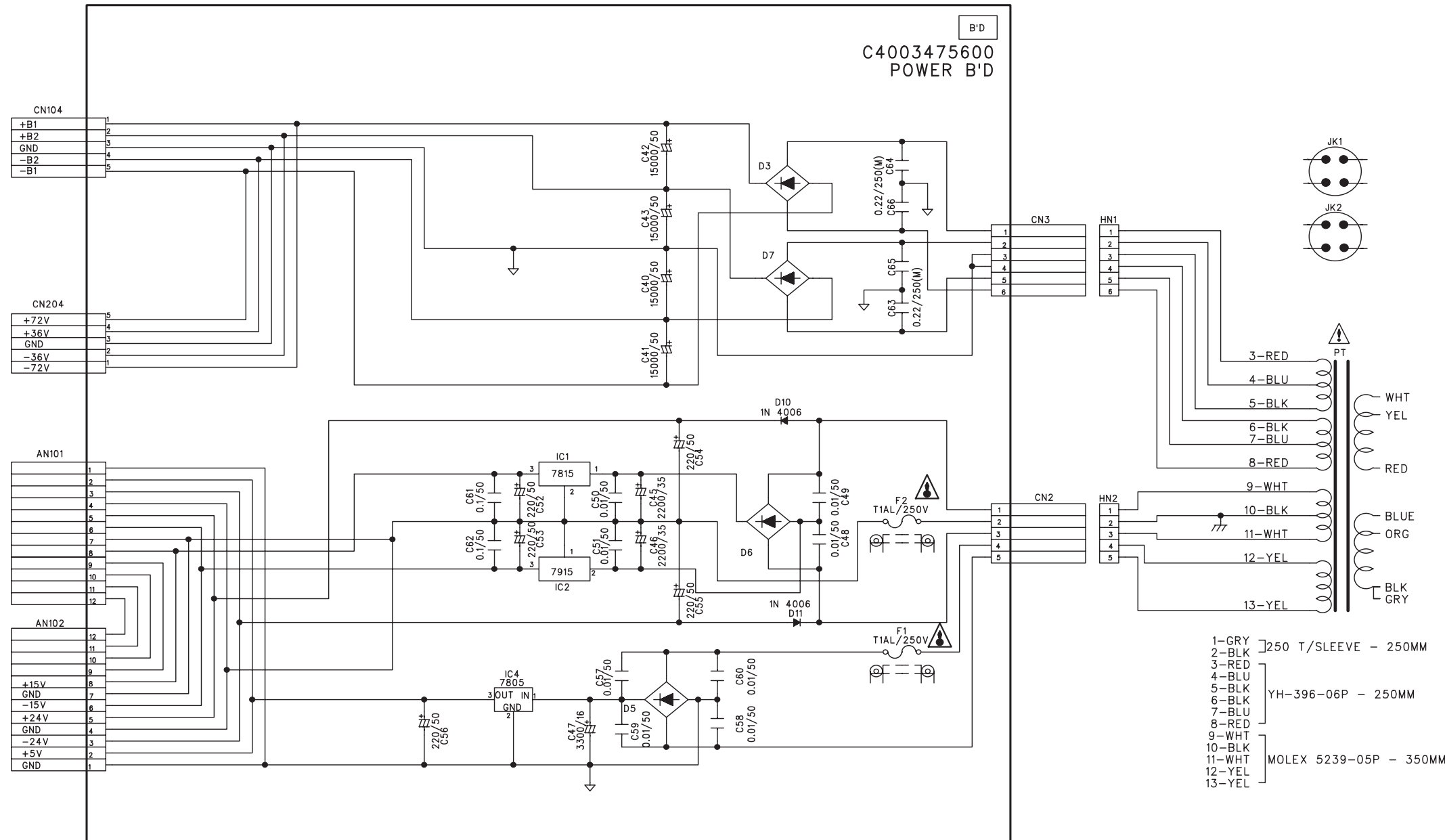

F3	F4
T6.3AL/250V	T6.3AL/250V
T6.3AL/250V	T6.3AL/250V
T6.35AL/250V	T6.3AL/250V

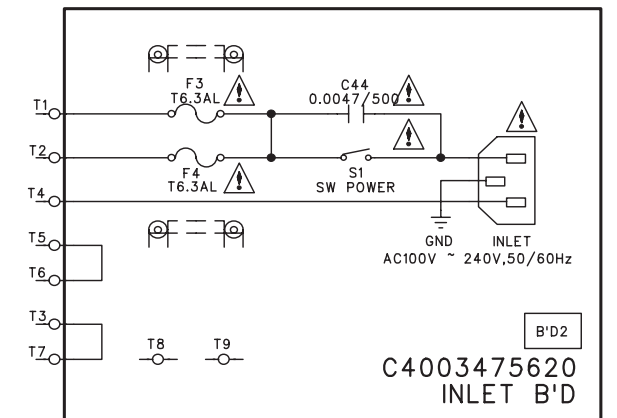

C4003475620
INLET B'D

	AC INPUT			
	100V	120V	220V	230V 240V
T1	YEL	BLUE	YEL	WHT
T2	ORG	WHT	X	X
T3	BLK	BLK	BLK	BLK
T4	GRY	GRY	GRY	GRY
T5	X	X	RED	RED
T6	X	X	BLUE	BLUE
T7	RED	RED	X	X
T8	WHT	YEL	WHT	YEL
T9	BLUE		ORG	ORG

- 1-GRY } 250 T/SLEEVE - 250MM
 - 2-BLK
 - 3-RED
 - 4-BLU
 - 5-BLK
 - 6-BLK
 - 7-BLU
 - 8-RED
 - 9-WHT
 - 10-BLK
 - 11-WHT
 - 12-YEL
 - 13-YEL
- YH-396-06P - 250MM
- MOLEX 5239-05P - 350MM

*SERVICE INFORMATION

1. RESISTANCE VALUES ARE INDICATED IN OHMS UNLESS OTHERWISE SPECIFIED.
(K=1,000, M=1,000,000)
2. CAPACITANCE VALUES ARE SHOWN IN MICROFARADS UNLESS OTHERWISE NOTED.
(P=MICRO-MICROFARADS)
3. ALL VOLTAGES ARE REFERRED TO GROUND UNDER THE FOLLOWING CONDITIONS.
DC:NO SIGNAL EXCEPT WHERE INDICATED.
AC:RMS
4. -PRECAUTION-
A) ALL COMPONENTS MARKED MUST BE REPLACED ONLY WITH ORIGINAL TYPE SPECIFIED BY THE MANUFACTURER. INTER M CORPORATION AND INSTALLED AS THE ORIGINAL SPACERS AND POSITIONED AWAY FROM ADJACENT COMPONENTS WHERE APPLICABLE.
B) ALL SOLDERING MUST BE DONE IN A PROFESSIONAL MANNER USING SOLDER WHITE RESINE CORE ONLY.
C) ALL COVERS, SHIELD AND INSULATING SPACERS MUST BE REPLACED BEFORE RETURNING APPLIANCE TO CUSTOMER.
D) A DAMAGE POWER SUPPLY CORD MUST BE REPLACED BEFORE RETURNING TO CUSTOMER.
E) DIELECTRIC TEST CONSISTING OF 120V AC 60HZ IS TO BE APPLIED BETWEEN BOTH BALDES OF THE POWER SUPPLY CIRD ATTACHMENT PLUG THE EXPOSE CONDUCTIVE SURFACE OF THE APPLIANCE FOR A PERIOD OF NOT LESS THAN ONE SECOND BEFORE RETURNING APPLIANCE TO CUSTOMER.
F) THE MARKED RESISTORS ARE MOUNTED THE P.C.B ON SLEEVES.

C4003475630
OUT JACK B'D

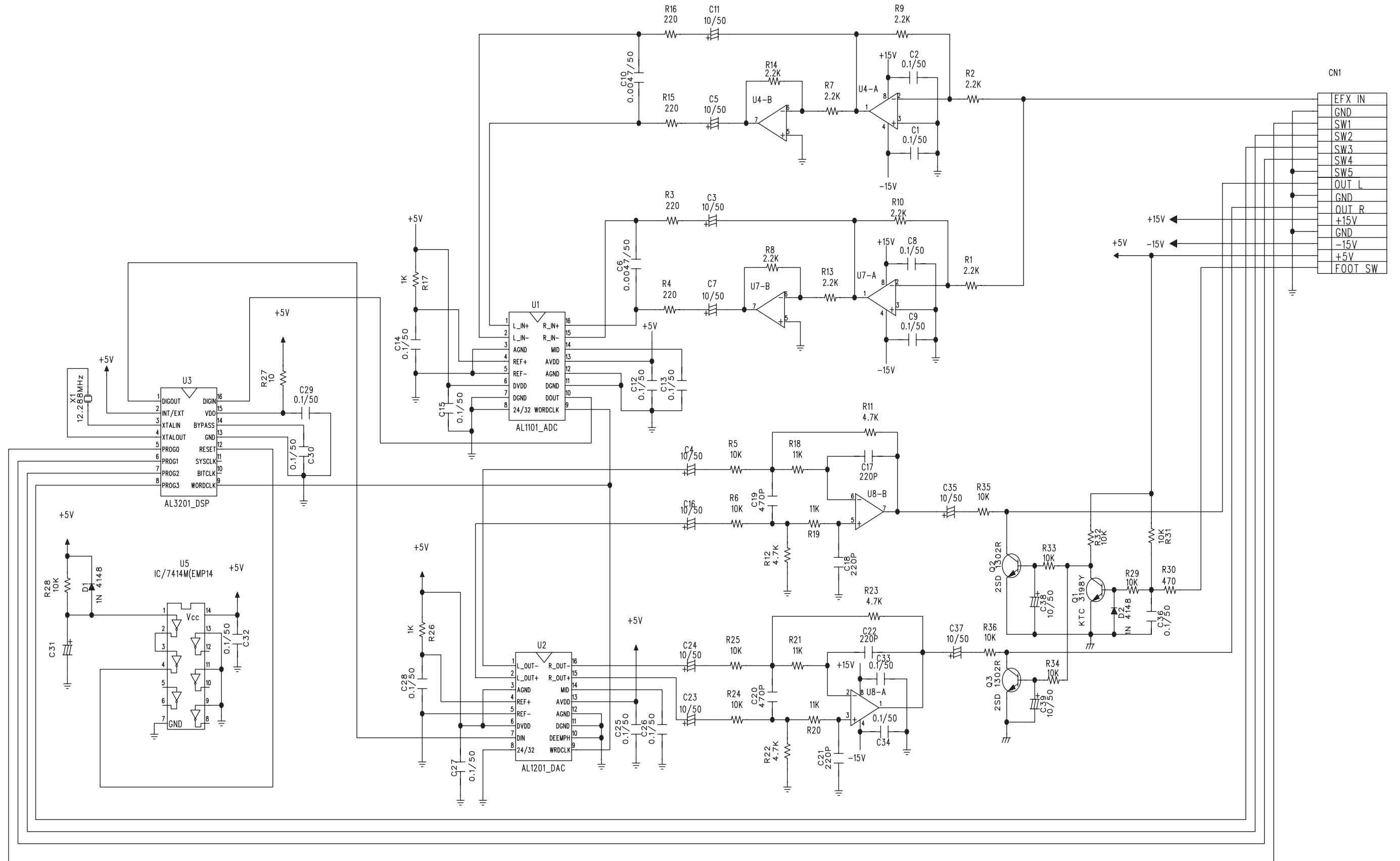

CN1	EFX IN
	GND
	SW1
	SW2
	SW3
	SW4
	SW5
	OUT L
	GND
	OUT R
	+15V
	GND
	-15V
	+5V
	FOOT SW

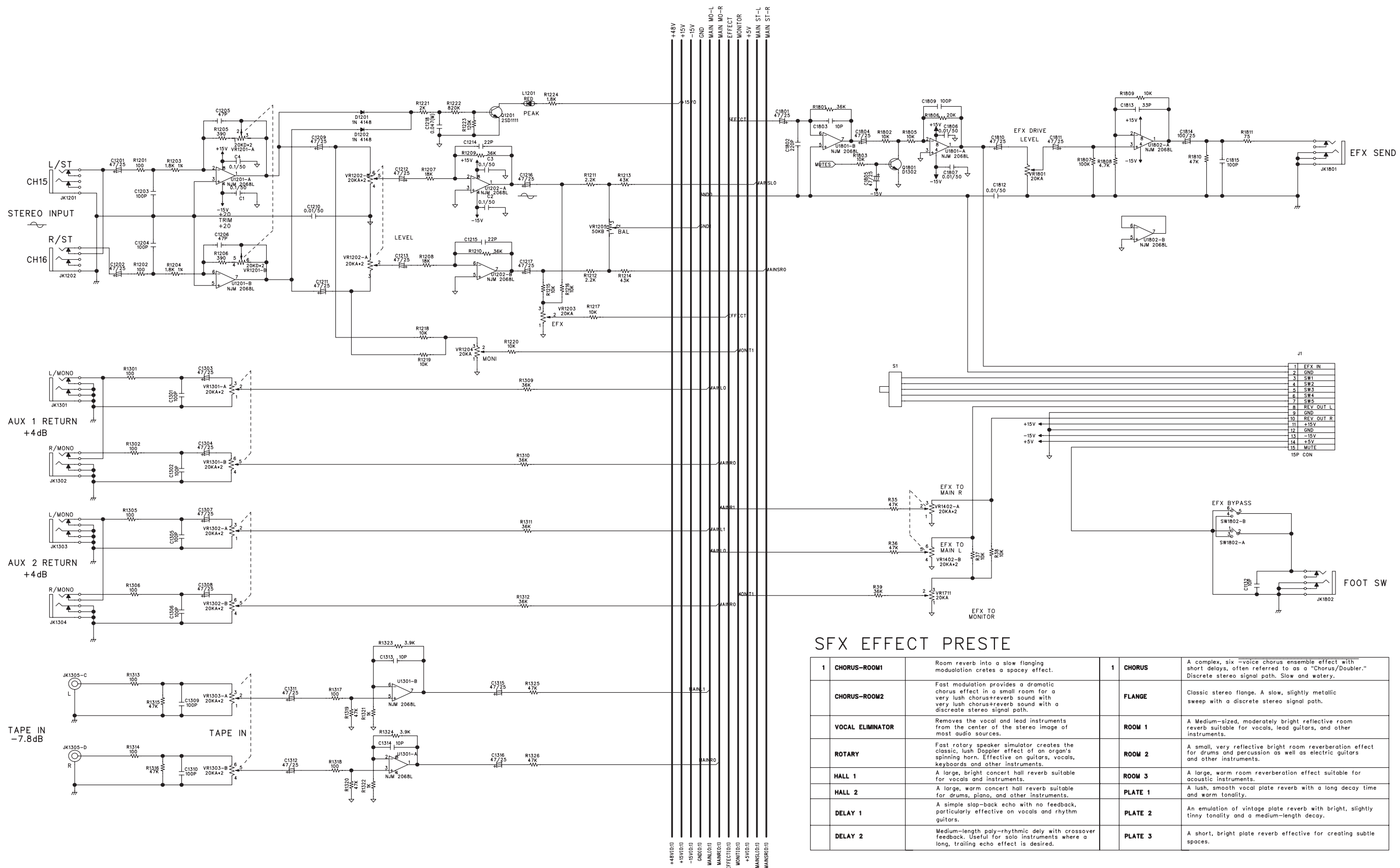

SFX EFFECT PRESTE

1	CHORUS-ROOM1	Room reverb into a slow flanging modulation creates a spacey effect.	1	CHORUS	A complex, six-voice chorus ensemble effect with short delays, often referred to as a "Chorus/Doubler." Discrete stereo signal path. Slow and watery.
	CHORUS-ROOM2	Fast modulation provides a dramatic chorus effect in a small room for a very lush chorus+reverb sound with very lush chorus+reverb sound with a discrete stereo signal path.		FLANGE	Classic stereo flange. A slow, slightly metallic sweep with a discrete stereo signal path.
	VOCAL ELIMINATOR	Removes the vocal and lead instruments from the center of the stereo image of most audio sources.		ROOM 1	A Medium-sized, moderately bright reflective room reverb suitable for vocals, lead guitars, and other instruments.
	ROTARY	Fast rotary speaker simulator creates the classic, lush Doppler effect of an organ's spinning horn. Effective on guitars, vocals, keyboards and other instruments.		ROOM 2	A small, very reflective bright room reverberation effect for drums and percussion as well as electric guitars and other instruments.
	HALL 1	A large, bright concert hall reverb suitable for vocals and instruments.		ROOM 3	A large, warm room reverberation effect suitable for acoustic instruments.
	HALL 2	A large, warm concert hall reverb suitable for drums, piano, and other instruments.		PLATE 1	A lush, smooth vocal plate reverb with a long decay time and warm tonality.
	DELAY 1	A simple slap-back echo with no feedback, particularly effective on vocals and rhythm guitars.		PLATE 2	An emulation of vintage plate reverb with bright, slightly tinny tonality and a medium-length decay.
	DELAY 2	Medium-length poly-rhythmic delay with crossover feedback. Useful for solo instruments where a long, trailing echo effect is desired.		PLATE 3	A short, bright plate reverb effective for creating subtle spaces.

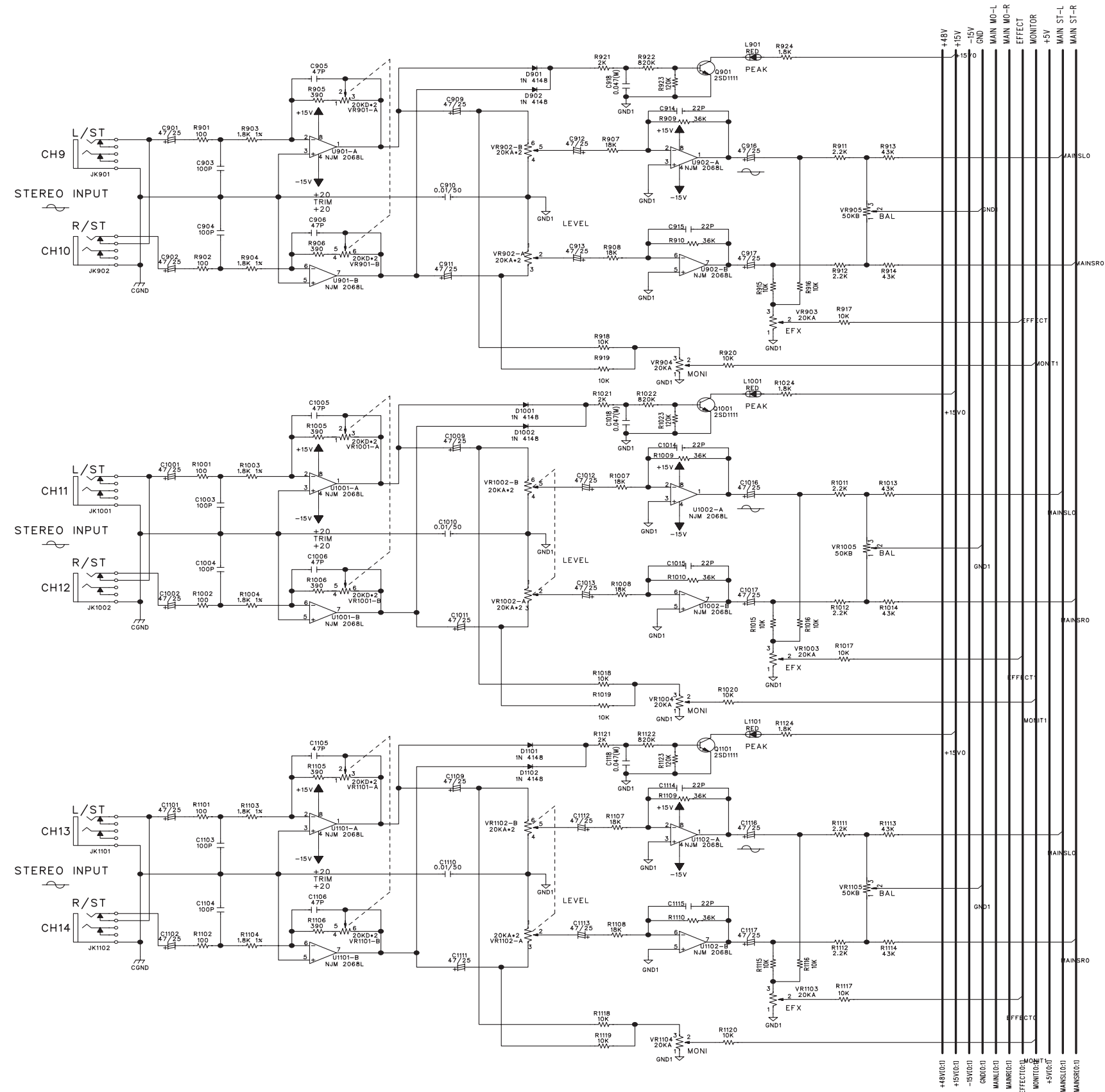

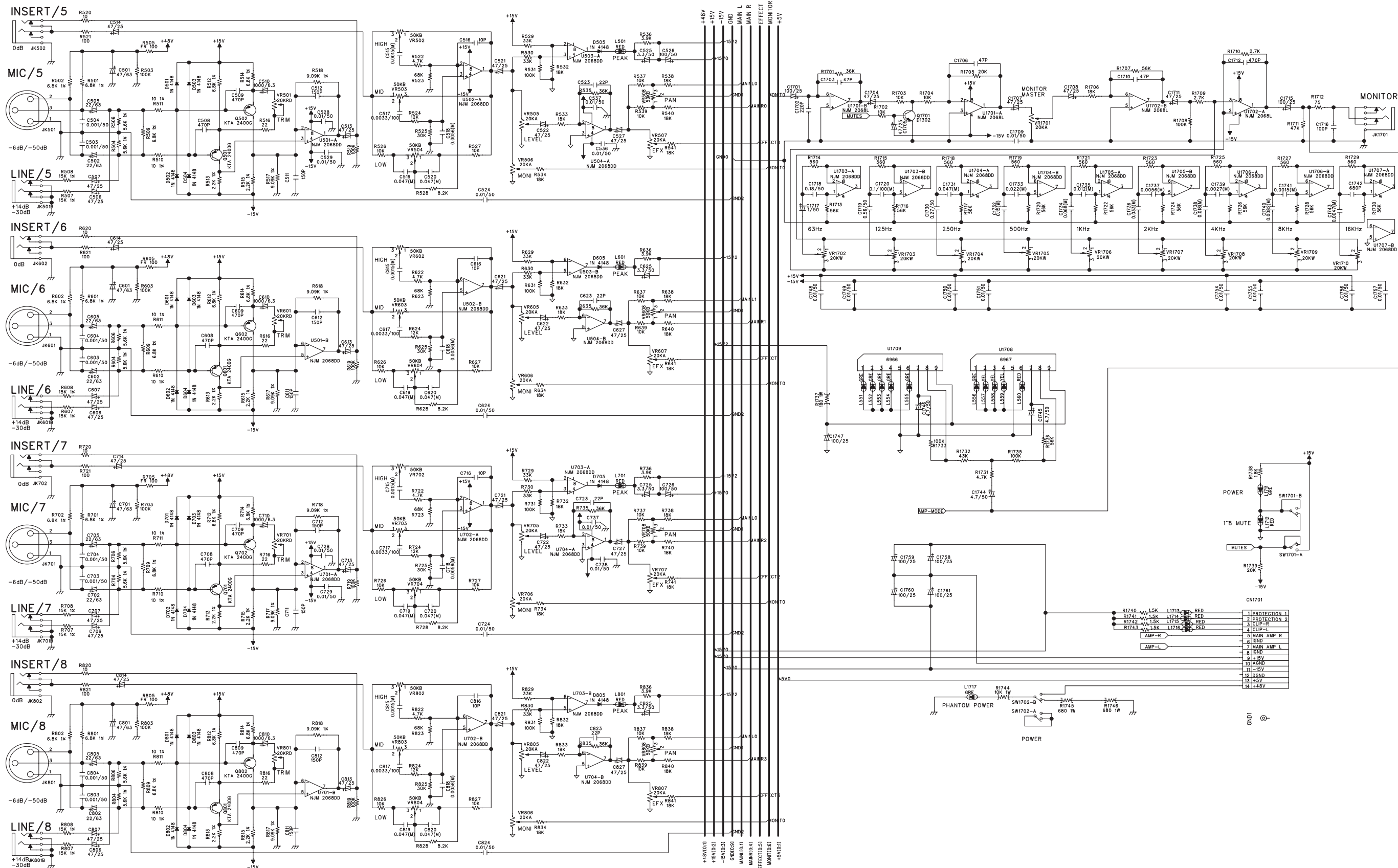

- 1 PROTECTION 1
- 2 PROTECTION 2
- 3 CLIP-R
- 4 CLIP-L
- 5 MAIN AMP R
- 6 GND
- 7 MAIN AMP L
- 8 +15V
- 9 GND
- 10 -15V
- 11 -15V
- 12 GND
- 13 +5V
- 14 +48V

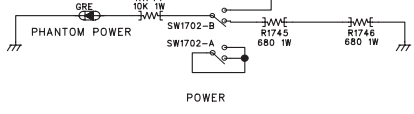

GND1

