

SERVICE

MANUAL

Q U A D S E R I E S

AMPLIFIER

QD-4240/4480

interM

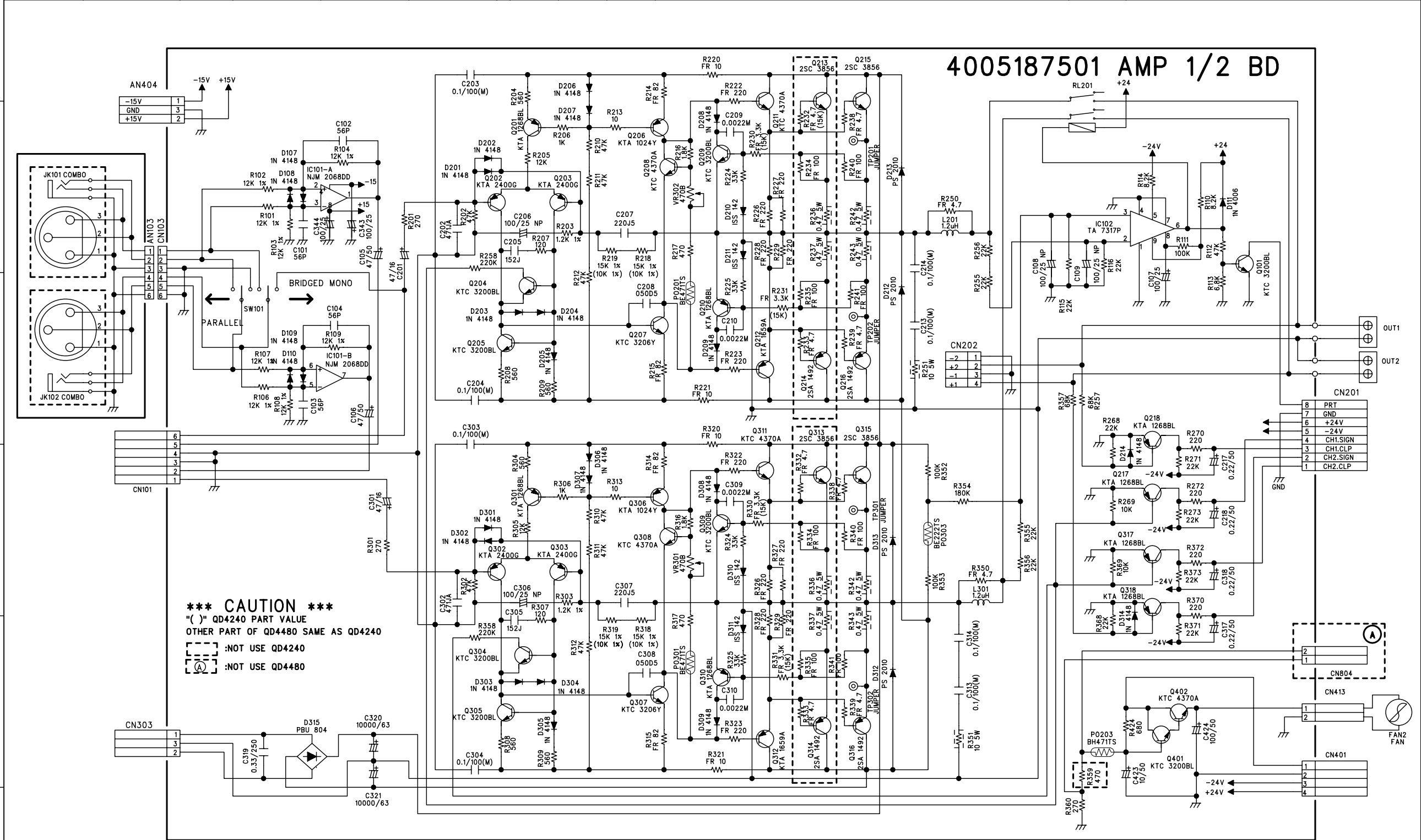

***** CAUTION *****
 () QD4240 PART VALUE
 OTHER PART OF QD4480 SAME AS QD4240
 [] :NOT USE QD4240
 (A) :NOT USE QD4480

***SERVICE INFORMATION**
 1.RESISTANCE VALUES ARE INDICATED IN OHMS UNLESS OTHERWISE SPECIFIED.
 (K=1,000, M=1,000,000)
 2.CAPACITANCE VALUES ARE SHOWN IN MICROFARADS UNLESS OTHERWISE NOTED.
 (P=MICRO-MICROFARADS)
 3.ALL VOLTAGES ARE REFERRED TO GROUND UNDER THE FOLLOWING CONDITIONS.
 DC:NO SIGNAL EXCEPT WHERE INDICATED.
 AC:RMS

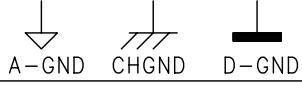

4005187570 AMP 3/4 BD

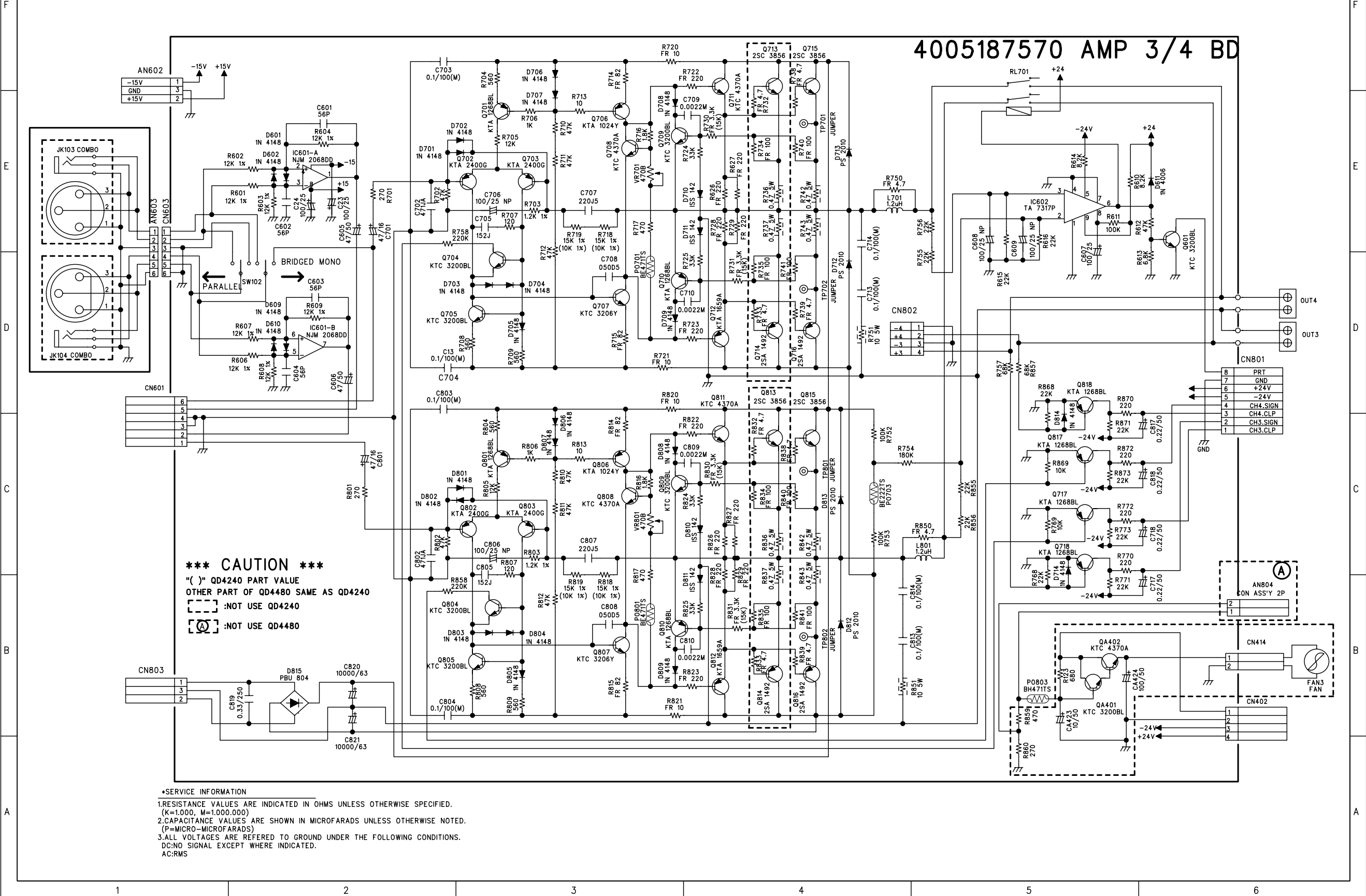

***** CAUTION *****
 (") QD4240 PART VALUE
 OTHER PART OF QD4480 SAME AS QD4240
 [] :NOT USE QD4240
 [A] :NOT USE QD4480

***SERVICE INFORMATION**
 1.RESISTANCE VALUES ARE INDICATED IN OHMS UNLESS OTHERWISE SPECIFIED.
 (K=1,000, M=1,000,000)
 2.CAPACITANCE VALUES ARE SHOWN IN MICROFARADS UNLESS OTHERWISE NOTED.
 (P=MICRO-MICROFARADS)
 3.ALL VOLTAGES ARE REFERRED TO GROUND UNDER THE FOLLOWING CONDITIONS.
 DC:NO SIGNAL EXCEPT WHERE INDICATED.
 AC:RMS

8	PRT
7	GND
6	+24V
5	-24V
4	CH4.SIGN
3	CH4.CLP
2	CH3.SIGN
1	CH3.CLP

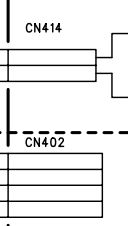
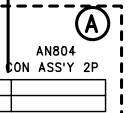

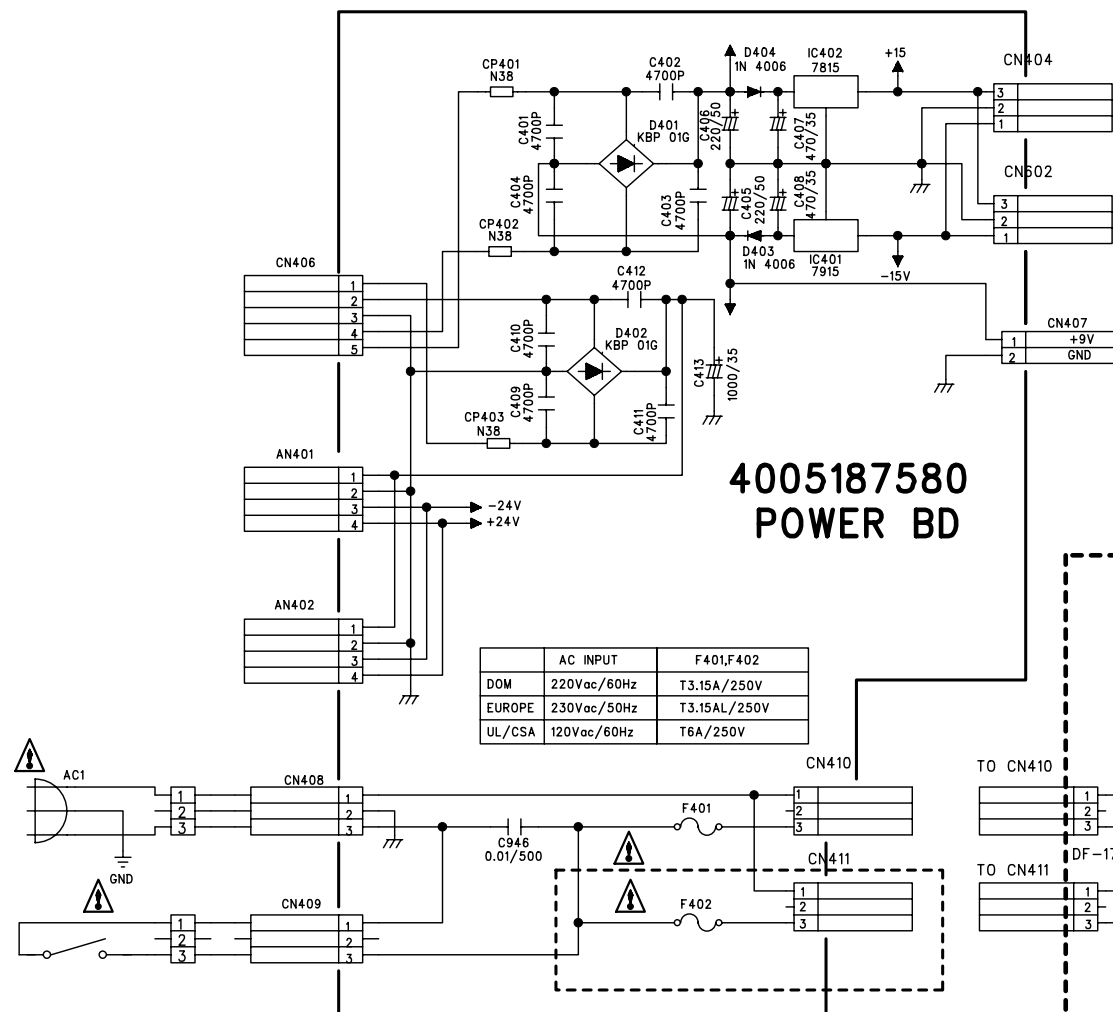

	AC INPUT	F401,F402
DOM	220Vac/60Hz	T3.15A/250V
EUROPE	230Vac/50Hz	T3.15AL/250V
UL/CSA	120Vac/60Hz	T6A/250V

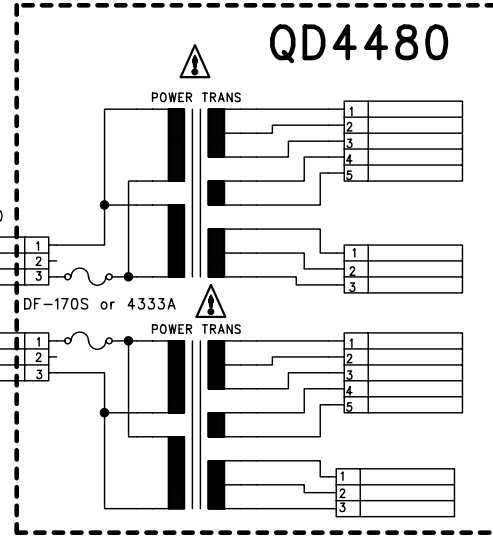
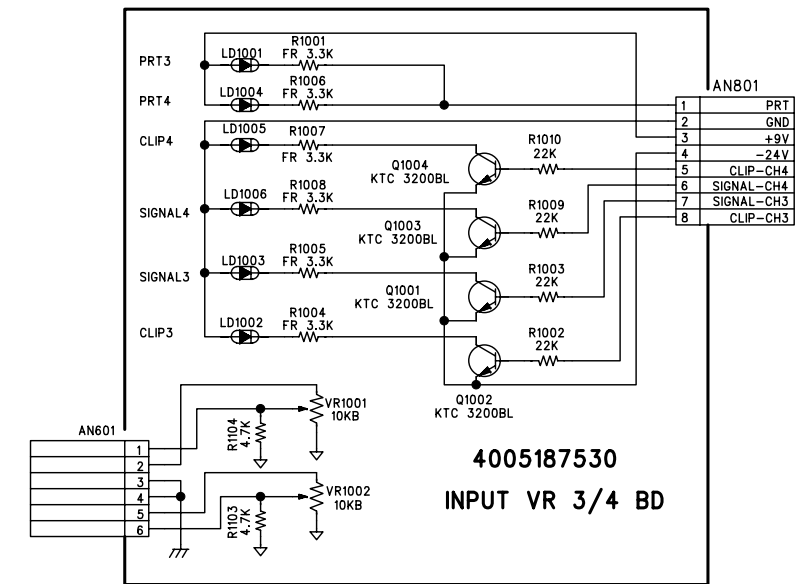
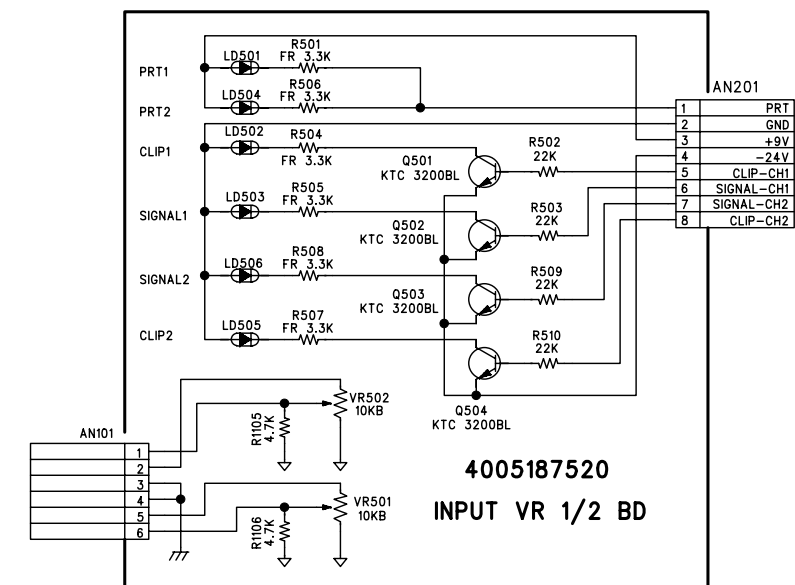
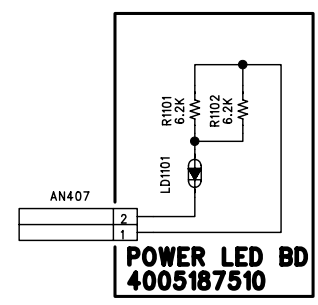

***** CAUTION *****
 (") QD4240 PART VALUE
 OTHER PART OF QD4480 SAME AS QD4240
 [] :NOT USE QD4240
 [A] :NOT USE QD4480

***SERVICE INFORMATION**

1. RESISTANCE VALUES ARE INDICATED IN OHMS UNLESS OTHERWISE SPECIFIED. (K=1,000, M=1,000,000)
2. CAPACITANCE VALUES ARE SHOWN IN MICROFARADS UNLESS OTHERWISE NOTED. (P=MICRO-MICROFARADS)
3. ALL VOLTAGES ARE REFERRED TO GROUND UNDER THE FOLLOWING CONDITIONS.
 DC:NO SIGNAL EXCEPT WHERE INDICATED.
 AC:RMS
4. PRECAUTION-
 - A) ALL COMPONENTS MARKED MUST BE REPLACED ONLY WITH ORIGINAL TYPE SPECIFIED BY THE MANUFACTURER. INTER M CORPORATION AND INSTALLED AS THE ORIGINAL SPACE AND POSITIONED AWAY FROM ADJACENT COMPONENTS WHERE APPLICABLE.
 - B) ALL SOLDERING MUST BE DONE IN A PROFESSIONAL MANNER USING SOLDER WHITE RESINE CORE ONLY.
 - C) ALL COVERS, SHIELD AND INSULATING SPACERS MUST BE REPLACED BEFORE RETURNING APPLIANCE TO CUSTOMER.
 - D) A DAMAGE POWER SUPPLY CORD MUST BE REPLACED BEFORE RETURNING TO CUSTOMER.
 - E) DIELECTRIC TEST CONSISTING OF 120V AC 60HZ IS TO BE APPLIED BETWEEN BOTH BALDES OF THE POWER SUPPLY CORD ATTACHMENT PLUG THE EXPOSE CONDUCTIVE SURFACE OF THE APPLIANCE FOR A PERIOD OF NOT LESS THAN ONE SECOND BEFORE RETURNING APPLIANCE TO CUSTOMER.
 - F) THE MARKED RESISTORS ARE MOUNTED THE P.C.B ON SLEEVES.

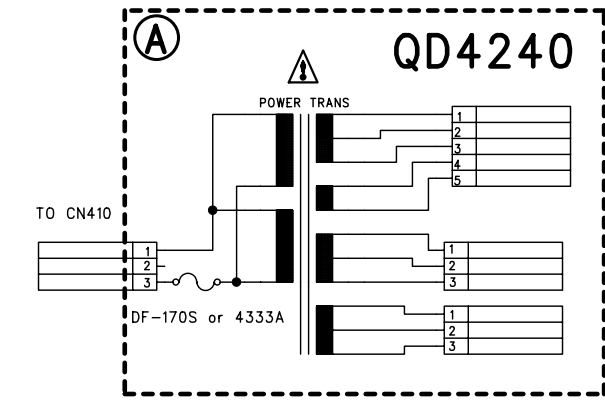

1	2		3			4		5		6		7		8		9
COMPANY	INTER.M	APPLICANT	REVISED NUMBER AND DATE			DRAWN	CHECKED	APPROVED	NOTE			SHEET NO.		SCHEMATIC DIAGRAM		
TYPE CODE			1.	4.	7.									MODEL : QD-4240 BLOCK DIAGRAM		
APPROVED DATE			2.	5.	8.											
			3.	6.	9.											

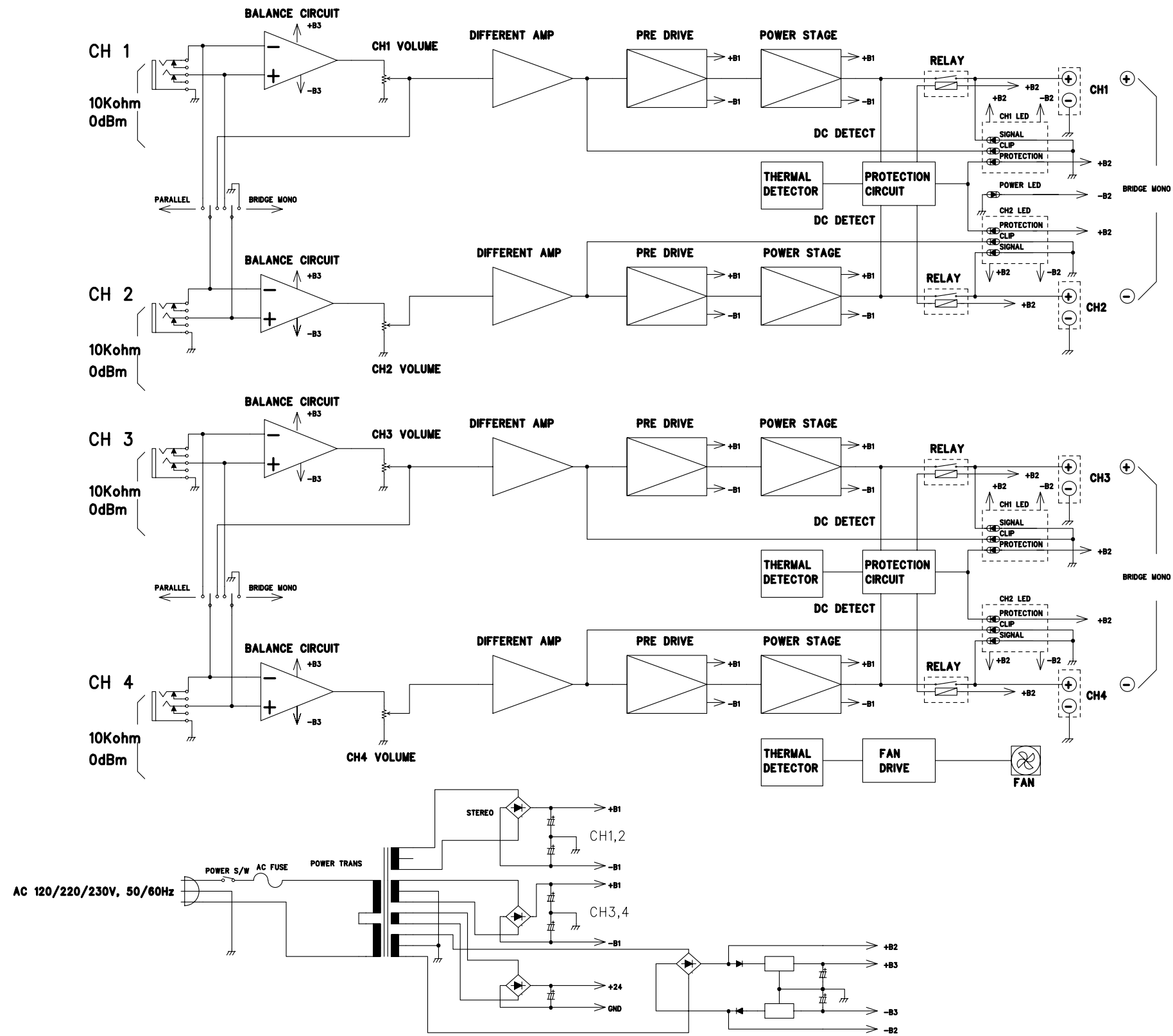

1		2		3		4		5		6		7		8		9	
COMPANY	INTER.M	APPLICANT	REVISED NUMBER AND DATE			S	DRAWN	CHECKED	APPROVED	NOTE	SHEET NO.		BLOCK DIAGRAM				
TYPE CODE			1.	4.	7.	G							MODEL : QD-4480				
APPROVED DATE			2.	5.	8.	N											
			3.	6.	9.												

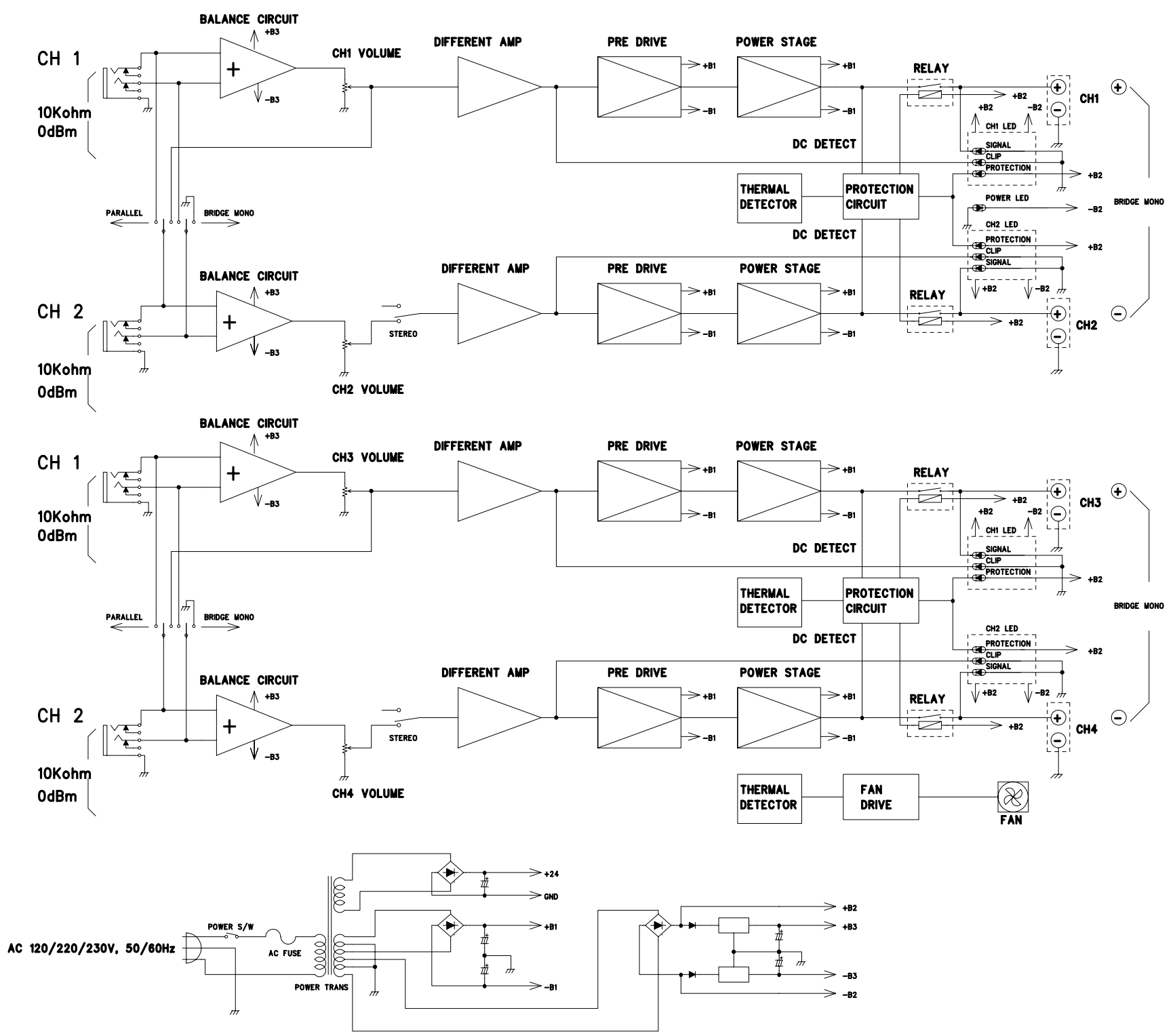

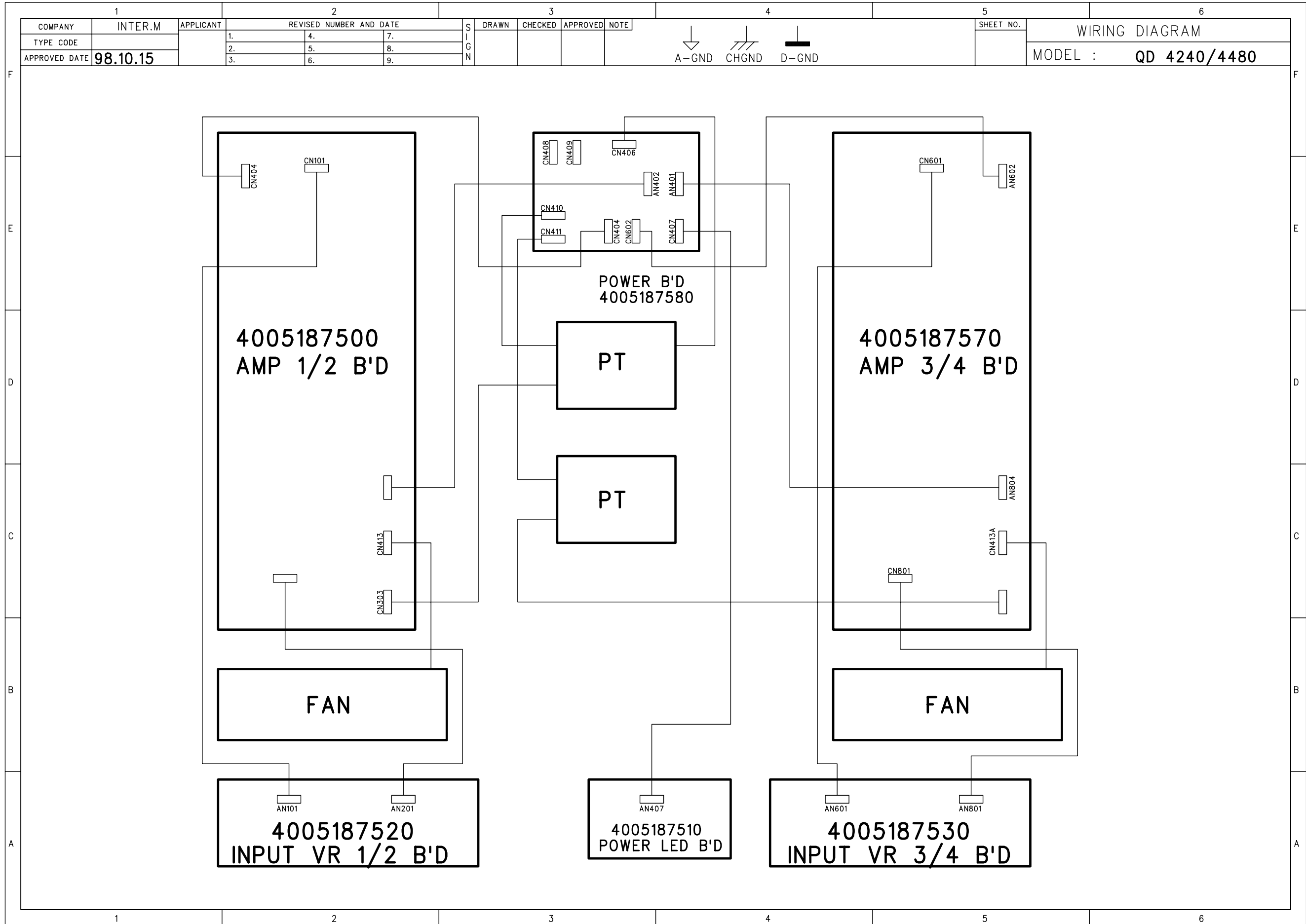

ELECTRICAL PARTS LIST (OD - 4240 / 4480)

Ref No.	Part No.	Description	Value	Qty
PCB AMP 1/2 B'D (4005187501)				
AN103	4355794903	CON ASSY 6P FLAT	ASSY 6P FLAT	1
AN404	4355863714	CONN' ASSY 3P PL-2404	ASSY 3P PL-2404	1
C101-104	3529560311-A	CAP CE SL 56PF 50V J AXIAL	56P	4
C105-106	3409247071-T	CAP AF RSG 47UF 50V 6 P	47/50	2
C107 C343-344	3409210141-T	CAP AF RSG 100UF 25V 6 P	100/25	3
C108-109 C206 C306	3409810141-T	CAP AF NP 100UF 25V	100/25 NP	4
C201 C301	3409547031-T	CAP AF 47UF 16V (MOSE)	47/16	2
C202 C302	3688471118	CAP MO SR22C 471JA	471JA	2
C203-204 C213-214 C303-304 C313-314	3609104122-T	CAP MA 0.1UF 100V J SMALL	0.1/100(M)	8
C205 C305	3698152198	CAP NPP POLY 152J 2J	152J	2
C207 C307	3678220177	CAP M1 DM 10C 220J5	220J5	2
C208 C308	3678050177	CAP M1 DM10C 050D5	050D5	2
C209-210 C309-310	3609222120-T	CAP MA 0.0022UF 100V J	0.0022M	4
C217-218 C317-318	3409222871-T	CAP AF RSG 0.22UF 50V 5 P	0.22/50	4
C319	3619334153	CAP POLY TM 0.33UF 250V	0.33/250	1
C320-321	3419510379	CAP E LPW103HJP63V-WGB3 JAMIC	10000/63	2
C423	3409210071-T	CAP AF RSG 10UF 50V 5 P	10/50	1
C424	3409210171-T	CAP AF RSG 100UF 50V 8 P	100/50	1
CN101 CN103	4428595006	LW5267/LWB0640/2.5MM-06P	WAFER/6P	2
CN201	4428595008	LW5267/LWB0640/2.5MM-08P	WAFER/8P	1
CN202	4355923804	CONNECTOR WAFER 04P (J.ST)	WAFER/04P(JST)	1
CN303	4355923801	CON WAFER B3P-VH JST(3.96)	WAFER/B3P	1
CN401	4428598304	WAFER LW-0640-4P	WAFER/4P	1
CN413	4428595003	CON WAFER A2505WV2-03P	WAFER/3P	1
CN804	4428595002	LW5267/LWB0640/2.5MM-02P	WAFER/2P	1
D107-110 D201-209 D214 D301-309 D314	2058304100	DIODE IN4148M	1N 4148	24
D111	2058100996	DIODE RECTIFIER LT1N4006(4007)	1N 4006	1
D210-211 D310-311	2058322100	DIODE 1SS145 ROHM	ISS 142	4
D212-213 D312-313	2058100110	DIODE RL207 PYUNG CHANG	PS 2010	4
D315	2058100988	DIODE BRIDGE PBU 804	PBU 804	1
FAN2	7308999010	FAN F8025*24B MA-430/830	FAN	1
IC101	2118010432	IC NJM2068DD JRC	NJM 2068DD	1
IC102	2118050410	IC TA7317P TOSHIBA	TA 7317P	1
JK101-102	4438090310	JACK COMBINATION CXL-06L	COMBO	2
JK1-2	4438090910	JACK XLR NC3FBH10 NEUTRIC	XLR 3P(F)	2
L201 L301	2648099940	COIL INDUCTOR 1.2UH	1.2uH	2
OUT1-2	4438191710	BINDING POST (2P) DOM.UL	BINDING POST	2
PO201 PO301	2438007994	POSISTOR PTFLO4BE471Q2N34B0	BE471TS	2
PO203	2438007995	POSISTOR PTFM04BH471Q2N34B0	BH471TS	1
PO303	2438007993	POSISTOR PTFM04BE222Q2N34B0	BE222TS	1
Q101 Q204-205 Q209 Q304-305 Q309 Q401	2008606108-T	KTC3200-BL-AT	KTC 3200BL	8
Q201 Q210 Q217-218 Q301 Q310 Q317-318	2008206104-T	KTA1268-BL-AT	KTA 1268BL	8
Q202-203 Q302-303	2008206106-T	KTA2400-GR-AT	KTA 2400G	4
Q206 Q306	2008206997-T	KTA1024-Y-AT	KTA 1024Y	2
Q207 Q307	2008606107-T	KTC3206-Y-AT	KTC 3206Y	2
Q208 Q211 Q308 Q311 Q402	2028407990	KTC4370A-Y-U	KTC 4370A	5
Q212 Q312	2028107984	KTA1659A-Y-U	KTA 1659A	2
Q213 Q215 Q313 Q315	2028427998	TR 2SC 3856 W/ACC	2SC 3856	4
Q214 Q216 Q314 Q316	2028117994	TR PNP 2SA 1492 W/ACC	2SA 1492	4
R101-104 R106-109	3002120953	RES CF 12K 1/5W FN	12K 1%	8
R110 R114	3009822973	RES CF 8.2K 1/5W J N	8.2K	2
R111 R352-353	3009104973	RES CF 100K 1/5W J N	100K	3
R112 R202 R210-212	3009473973	RES CF 47K 1/5W J N	47K	9

R302 R310-312				
R113	3009682973	RES CF 6.8K 1/5W J N	6.8K	1
R115-116 R255-256 R268 R271 R273 R355-356 R368 R371 R373	3009223973	RES CF 22K 1/5W J N	22K	12
R201 R301	3009271973	RES CF 270 1/5W J N	270	2
R203 R303	3003120953	RES CF 1.2K 1/5W FN	1.2K 1%	2
R204 R208-209 R304 R308-309	3009561973	RES CF 560 1/5W J N	560	6
R205 R305	3009123973	RES CF 12K 1/5W J N	12K	2
R206 R306	3009102973	RES CF 1K 1/5W J N	1K	2
R207 R307	3009121973	RES CF 120 1/5W J N	120	2
R213 R313	3009100973	RES CF 10 1/5W J N	10	2
R214-215 R314-315	3089820275	RES NFR 82 1/4W J R PHILKO	FR 82	4
R216 R316	3009182973	RES CF 1.8K 1/5W J N	1.8K	2
R217 R317 R359	3009471973	RES CF 470 1/5W J N	470	3
R218-219 R318-319	3002150953	RES CF 15K 1/5W F N	15K 1%	4
R220-221 R320-321	3089100275	RES NFR 10 1/4W J R PHILKO	FR 10	4
R234-235 R240-241 R334-335 R340-341	3079101275	RES ERD-2FCVG 101T 1/4W R	FR 100	8
R222-223 R226-229 R322-323 R326-329	3089221275	RES NFR 220 1/4W J R PHILKO	FR 220	12
R224-225 R324-325	3009333973	RES CF 33K 1/5W J N	33K	4
R230-231 R330-331	3089332275	RES NFR 3.3K 1/4W J R PHILKO	FR 3.3K	4
R232-233 R238-239 R250 R332-333 R338-339 R350	3089479275	RES NFR 4.7 1/4W J R PHILKO	FR 4.7	10
R236-237 R242-243 R336-337 R342-343	3059478783	RES CE 0.47 5W J T	0.47 5W	8
R251 R351	3059100772	RES CE 10 5W JN	10 5W	2
R257 R357	3009683973	RES CF 68K 1/5W J N	68K	2
R258 R358	3009224973	RES CF 220K 1/5W J N	220K	2
R269 R369	3009103973	RES CF 10K 1/5W J N	10K	2
R270 R272 R370 R372	3009221973	RES CF 220 1/5W J N	220	4
R354	3009184973	RES CF 180K 1/5W J N	180K	1
R360	3009271973	RES CF 270 1/5W J N	270	1
R424	3009681973	RES CF 680 1/5W J N	680	1
RL201	5528009950	RELAY HR-CR3A23 DC 24VH	CR323	1
SW101	3238084110	SLIDE SW (SSAF 123NB011)	3-POS	1
TP201-202 TP301-302	1508400501	JUMP WIRE(0.5/52M/M)	JUMPER	4
VR301-302	3248347110	RES SEMI RH 0614C100471	470B	2
PCB AMP 3/4 B'D (4005187570)				
AN804	4355838116	CON ASSY 2P (PB-9207A)	CON ASSY 2P	1
AN602	4355863714	CONN ASSY 3P PL-2404	ASSY 3P PL-2404	1
AN603	4355794903	CON ASSY 6P FLAT	ASSY 6P FLAT	1
C702 C802	3688471118	CAP MO SR22C 471JA	471JA	2
C707 C807	3678220177	CAP M1 DM 10C 220J5	220J5	2
C705 C805	3698152198	CAP NPP POLY 152J 2J	152J	2
C708 C808	3678050177	CAP M1 DM10C 050D5	050D5	2
C701 C801	3409547031-T	CAP AF 47UF 16V (MOSE)	47/16	2
C820-821	3419510379	CAP E LPW103HJP63V-WGB3 JAMIC	10000/63	2
C601-604	3529560311-A	CAP CE SL 56PF 50V J AXIAL	56P	4
C717-718 C817-818	3409222871-T	CAP AF RSG 0.22UF 50V 5 P	0.22/50	4
C608-609 C706 C806	3409810141-T	CAP AF NP 100UF 25V	100/25 NP	4
C23-24 C607	3409210141-T	CAP AF RSG 100UF 25V 6 P	100/25	3
C605-606	3409247071-T	CAP AF RSG 47UF 50V 6 P	47/50	2
C709-710 C809-810	3609222120-T	CAP MA 0.0022UF 100V J	0.0022M	4
C13 C703 C713-714 C803-804 C813-814	3609104122-T	CAP MA 0.1UF 100V J SMALL	0.1/100(M)	8
C819	3619334153	CAP POLY TM 0.33UF 250V	0.33/250	1
CA423	3409210071-T	CAP AF RSG 10UF 50V 5 P	10/50	1

CA424	3409210171-T	CAP AF RSG 100UF 50V 8 P	100/50	1
CN414	4428595003	LW5267/LWB0640/2.5MM-03P	WAFER/3P	1
CN803	4355923801	CON WAFER B3P-VH JST(3.96)	WAFER/B3P	1
CN402	4428598304	WAFER LW-0640-4P	WAFER/4P	1
CN802	4355923804	CONNECTOR WAFER 04P (J.ST)	WAFER/04P(JST)	1
CN601 CN603	4428595006	LW5267/LWB0640/2.5MM-06P	WAFER/6P	2
CN801	4428595008	LW5267/LWB0640/2.5MM-08P	WAFER/8P	1
D815	2058100988	DIODE BRIDGE PBU 804	PBU 804	1
D611	2058100996	DIODE RECTIFIER LT1N4006(4007)	1N 4006	1
D601-602 D609-610 D701-709 D714 D801-809 D814	2058304100	DIODE IN4148M	1N 4148	24
D710-711 D810-811	2058322100	DIODE 1SS145 ROHM	ISS 142	4
D712-713 D812-813	2058100110	DIODE RL207 PYUNG CHANG	PS 2010	4
FAN3	7308999010	FAN F8025*24B MA-430/830	FAN	1
IC601	2118010432	IC NJM2068DD JRC	NJM 2068DD	1
IC602	2118050410	IC TA7317P TOSHIBA	TA 7317P	1
JK103-104	4438090310	JACK COMBINATION CXLF-06L	COMBO	2
JK3-4	4438090910	JACK XLR NC3FBH10 NEUTRIC	XLR 3P(F)	2
L701 L801	2648099940	COIL INDUCTOR 1.2UH	1.2uH	2
OUT3-4	4438191710	BINDING POST (2P) DOM.UL	BINDING POST	2
PO701 PO801	2438007994	POSISTOR PTFLO4BE471Q2N34B0	BE471TS	2
PO703	2438007993	POSISTOR PTFM04BE222Q2N34B0	BE222TS	1
PO803	2438007995	POSISTOR PTFM04BH471Q2N34B0	BH471TS	1
Q708 Q711 Q808 Q811 QA402	2028407990	KTC4370A-Y-U	KTC 4370A	5
Q713 Q715 Q813 Q815	2028427998	TR 2SC 3856 W/ACC	2SC 3856	4
Q707 Q807	2008606107-T	KTC3206-Y-AT	KTC 3206Y	2
Q601 Q704-705 Q709 Q804-805 Q809 QA401	2008606108-T	KTC3200-BL-AT	KTC 3200BL	8
Q714 Q716 Q814 Q816	2028117994	TR PNP 2SA 1492 W/ACC	2SA 1492	4
Q712 Q812	2028107984	KTA1659A-Y-U	KTA 1659A	2
Q701 Q710 Q717-718 Q801 Q810 Q817-818	2008206104-T	KTA1268-BL-AT	KTA 1268BL	8
Q702-703 Q802-803	2008206106-T	KTA2400-GR-AT	KTA 2400G	4
Q706 Q806	2008206997-T	KTA1024-Y-AT	KTA 1024Y	2
R736-737 R742-743 R836-837 R842-843	3059478783	RES CE 0.47 5W J T	0.47 5W	8
R703 R803	3003120953	RES CF 1.2K 1/5W FN	1.2K 1%	2
R716 R816	3009182973	RES CF 1.8K 1/5W J N	1.8K	2
R734-735 R740-741 R834-835 R840-841	3079101275	RES ERD-2FCVG 101T 1/4W R	FR 100	8
R611 R752-753	3009104973	RES CF 100K 1/5W J N	100K	3
R713 R813	3009100973	RES CF 10 1/5W J N	10	2
R720-721 R820-821	3089100275	RES NFR 10 1/4W J R PHILKO	FR 10	4
R751 R851	3059100772	RES CE 10 5W JN	10 5W	2
R769 R869	3009103973	RES CF 10K 1/5W J N	10K	2
R707 R807	3009121973	RES CF 120 1/5W J N	120	2
R601-604 R606-609	3002120953	RES CF 12K 1/5W FN	12K 1%	8
R705 R805	3009123973	RES CF 12K 1/5W J N	12K	2
R718-719 R818-819	3002150953	RES CF 15K 1/5W F N	15K 1%	4
R754	3009184973	RES CF 180K 1/5W J N	180K	1
R706 R806	3009102973	RES CF 1K 1/5W J N	1K	2
R770 R772 R870 R872	3009221973	RES CF 220 1/5W J N	220	4
R626-627 R722-723 R728-729 R822-823 R826-829	3089221275	RES NFR 220 1/4W J R PHILKO	FR 220	12
R758 R858	3009224973	RES CF 220K 1/5W J N	220K	2
R615-616 R755-756 R768 R771 R773 R855-856 R868 R871 R873	3009223973	RES CF 22K 1/5W J N	22K	12
R701 R801	3009271973	RES CF 270 1/5W J N	270	2

R730-731 R830-831	3089332275	RES NFR 3.3K 1/4W J R PHILKO	FR 3.3K	4
R724-725 R824-825	3009333973	RES CF 33K 1/5W J N	33K	4
R732-733 R738-739 R750 R832-833 R838-839 R850	3089479275	RES NFR 4.7 1/4W J R PHILKO	FR 4.7	10
R717 R817 R859	3009471973	RES CF 470 1/5W J N	470	3
R612 R702 R710-712 R802 R810-812	3009473973	RES CF 47K 1/5W J N	47K	9
R704 R708-709 R804 R808-809	3009561973	RES CF 560 1/5W J N	560	6
R860	3009271973	RES CF 270 1/5W J N	270	1
R613	3009682973	RES CF 6.8K 1/5W J N	6.8K	1
R123	3009681973	RES CF 680 1/5W J N	680	1
R757 R857	3009683973	RES CF 68K 1/5W J N	68K	2
R610 R614	3009822973	RES CF 8.2K 1/5W J N	8.2K	2
R714-715 R814-815	3089820275	RES NFR 82 1/4W J R PHILKO	FR 82	4
RL701	5528009950	RELAY HR-CR3A23 DC 24VH	CR323	1
SW102	3238084110	SLIDE SW (SSAF 123NB011)	3-POS	1
TP701-702 TP801-802	1508400501	JUMP WIRE(0.5/52M/M)	JUMPER	4
VR701 VR801	3248347110	RES SEMI RH 0614C100471	470B	2
PCB INPUT VR 1/2 B'D (4005187520)				
AN101	4355788800	CON ASSY 6P S/D	CON ASSY 6P S/D	1
AN201	4355842415	CON ASSY 8P "73"	ASSY 8P "73"	1
LD501 LD504	2308232264	LED REF EL 204GD R3 GRE E-L	GRE(EL204GD)	2
LD502-503 LD505-506	2308232222	LED REF SLR-34UR R3 RED ROHM	RED(SLR34UR)	4
Q501-504	2008606108-T	KTC3200-BL-AT	KTC 3200BL	4
R502-503 R509-510	3009223973	RES CF 22K 1/5W J N	22K	4
R501 R504-508	3089332275	RES NFR 3.3K 1/4W J R PHILKO	FR 3.3K	6
R1105-1106	3009472973	RES CF 4.7K 1/5W J N	4.7K	2
VR501-502	3228070100	VR RK16311E0Z0113B (21DETENT)	10KB	2
PCB INPUT VR 3/4 B'D (4005187530)				
AN601	4355788800	CON ASSY 6P S/D	CON ASSY 6P S/D	1
AN801	4355842415	CON ASSY 8P "73"	ASSY 8P "73"	1
LD1001 LD1004	2308232264	LED REF EL 204GD R3 GRE E-L	GRE(EL204GD)	2
LD1002-1003 LD1005-1006	2308232222	LED REF SLR-34UR R3 RED ROHM	RED(SLR34UR)	4
Q1001-1004	2008606108-T	KTC3200-BL-AT	KTC 3200BL	4
R1002-1003 R1009-1010	3009223973	RES CF 22K 1/5W J N	22K	4
R1001 R1004-1008	3089332275	RES NFR 3.3K 1/4W J R PHILKO	FR 3.3K	6
R1103-1104	3009472973	RES CF 4.7K 1/5W J N	4.7K	2
VR1001-1002	3228070100	VR RK16311E0Z0113B (21DETENT)	10KB	2
PCB POWER B'D (4005187580)				
AN401-402	4355917215	CONNECTOR ASSY 4P	CON ASSY 4P	2
C946	3549103107	CAP DE2F3KH103MA4B	0.01/500	1
C401-404 C409-412	3509472950-T	CAP CE F 4700PF 500V Z	4700P	8
C413	3408210261	CAP RSG 1000UF 35V SNAP 16 P	1000/35	1
C405-406	3409222171-T	CAP AF RSG 220UF 50V SG 10 P	220/50	2
C407-408	3408247169	CAP AF SG 470UF 35V	470/35	2
CN408-409	4355923803	CONNECTOR WAFER 03P(J.ST)	WAFER 03P (JST)	2
CN407	4428595002	LW5267/LWB0640/2.5MM-02P	WAFER/2P	1
CN404 CN602	4428595003	LW5267/LWB0640/2.5MM-03P	WAFER/3P	2
CN410-411	4355923803	CONNECTOR WAFER 03P(J.ST)	WAFER 03P (JST)	2
CN406	4428595005	LW5267/LWB0640/2.5MM-05P	WAFER/5P	1
CP401-403	5528009834	ICP N38 1.5A ROHM	N38	3
D401-402	2058100979	DIODE BRIDGE (KBP01G/KBP153G)	KBP 01G	2
D403-404	2058100996	DIODE RECTIFIER LT1N4006(4007)	1N 4006	2
F401-402	5508413034	FUSE 218T20MM 3.15A/250V UCCKJ	T3.15AL/250V	2
IC401	2128610800	IC MC7915 COMMON	7915	1
IC402	2128610900	IC KA7815 COMMON	7815	1

PCB LED B'D (4005187510)				
AN407	4355838116	CON ASSY 2P (PB-9207A)	CON ASSY 2P	1
LD1101	2300050100 8545993390	LED LTL-307E LITEON LED LIMITER	LED RED	1
R1101-1102	3009622973	RES CF 6.2K 1/5W J N	6.2K	2
ASS'Y PARTS				
AC CORD	4448997410 4308997310 4308996710 4308998000 4308999310 4308999410	AC INLET 6100.4315 250T SCURTE AC CORD DOME 3-CORES AC CORD (WITHOUT PLUG) AC CORD POWER FOR SAA AC CORD UL 3 (INLET) AC CORD V+VII6A-250VHOVV-F3G	() C () D (4480) E () R (4480) B , R (4240)	1 1 1 1 1
ASSY	4355795508 4355788900 4355789014 4355789018 4355789603	CON ASSY 1P Y-G #18 250-RING CON ASSY 4P JST3.96 CON ASSY 3P 250T CON ASSY 3P 250T CON ASSY 2P FAN		
CN2-4 CN13 CN15-16 CN20 CN24-25	4355923803	CONNECTOR WAFER 03P(J.ST)	WAFER 03P(JST)	9
CN1 CN12 CN14	4428595005	LW5267/LWB0640/2.5MM-05P	WAFER/5P	3
FUSE	5508413034 5508213039 5508413038 5508413036 5508413539	FUSE 218T20MM 3.15A/250V UCSKJ FUSE#217F20MM 3.15A/250V UCSKJ FUSE#218T20MM 3.15A/250V UCSKJ FUSETS 20MM 3.15A/250V U/C/S/V FUSE#218T 20MM 6.3A/250V UCSKJ	T3.15AL/250V () C , R (4480) B , C , R (4240) D (4480) E ()	3 2 2 2 2
PT	2828067520 2828067500 2828067510 2828067530 2828067410 2828067420 2828067400	TRANS POWER 230V QD-4480 TRTANS POWER 120V QD-4480 TRANS POWER 220V QD-4480 TRANS POWER 240V QD-4480 TRANS POWER 220V QD-4240 TRANS POWER 230V QD-4240 TRANS POWER 120V QD4240	C , R (4480) E (4480) (4480) D (4480) () B , C , R (4240) E (4240)	3 2
SW POWER	4625996610 4625996611	SW POWER (C1550AT) SW POWER(C1350AT) ARCOLECTRIC	() C , D , E , R (4480) B , C , E , R (4240)	1