

SERVICE

MANUAL

A U D I O
MIXER

MX-1243

interM

ELECTRICAL PARTS LIST (MX - 1243)

Ref No.	Part No.	Description	Value	Qty	Remark
INPUT B'D					
CN1	4428592820	WAFER BOX 20P TPHAB03-1419-20A	20P	1	
XN1	4438193810	XLR JACK(F) 3P(E203A0040N)	E203A004	1	
SW1-2	4628983710	SW PUSH JPS 2254AS JAEIL	JPS2254AS	2	
Q1-2	2008206106-T	KTA2400-GR-AT	KTA2400G	2	
C24	3509100130-T	CAP CE SL 10PF 50V D	10P	1	
Q3-4	2008606108-T	KTC3200-BL-AT	KTC 3200BL	2	
Q5	2008613000-T	TR NPN 2SD1111 (SANYO,NEC)	2SD1111	1	
D1-5	2058304100	DIODE IN4148M	1N 4148	5	
U1-2	2118010432	IC NJM2068DD JRC	NJM 2068D	2	
LD1	2300030105	LED LTL-1CHE-021A LITEON	SLR34URF(RED)	1	
R25-26	3002270953	RES CF 27K 1/5W FN	27K 1%	2	
R20 R24	3003220953	RES CF 2.2K 1/5W F N	2.2K 1%	2	
R18 R21	3003820953	RES CF 8.2K 1/5W FN	8.2K 1%	2	
R37 R41	3009101973	RES CF 100 1/5W J N	100	2	
R12-13 R16-17	3009100973	RES CF 10 1/5W J N	10	4	
R35-36 R39	3009103973	RES CF 10K 1/5W J N	10K	3	
R51	3009105973	RES CF 1M 1/5W J N	1M	1	
R30	3009123973	RES CF 12K 1/5W J N	12K	1	
R3-4	3009153973	RES CF 15K 1/5W J N	15K	2	
R53	3009182973	RES CF 1.8K 1/5W J N	1.8K	1	
R42-48	3009183973	RES CF 18K 1/5W J N	18K	7	
R52	3009184973	RES CF 180K 1/5W J N	180K	1	
R50	3009202973	RES CF 2K 1/5W J N	2K	1	
R31	3009203973	RES CF 20K 1/5W J N	20K	1	
R40	3009223973	RES CF 22K 1/5W J N	22K	1	
R29	3009332973	RES CF 3.3K 1/5W J N	3.3K	1	
R22	3009430973	RES CF 43 1/5W J N	43	1	
R5-6 R14-15 R34 R38	3009473973	RES CF 47K 1/5W J N	47K	6	
R9-10	3009474973	RES CF 470K 1/5W J N	470K	2	
R7-8	3009471973	RES CF 470 1/5W J N	470	2	
R19 R23	3009681973	RES CF 680 1/5W J N	680	2	
R1-2 R11	3009682973	RES CF 6.8K 1/5W J N	6.8K	3	
R33	3009822973	RES CF 8.2K 1/5W J N	8.2K	1	
R32 R49	3009823973	RES CF 82K 1/5W J N	82K	2	
R27-28	3009912973	RES CF 9.1K 1/5W JN	9.1K	2	
FR2-3	3089100275	RES NFR 10 1/4W J R PHILKO	FR 10	2	
FR1	3089470275	RES NFR 47 1/4W JR PHILKO	FR 47	1	
VR10	3238081810	VR RA6040-30-15D1-A14-008	10KA	1	
VR1	3238087310	VR EVU JE9FK 424Y 20K	20KRD	1	
VR5-8	3238088610	VR EVU E2J FK4 A24 20KA	20KA	4	
VR9	4438192910	PHONE JACK (5P) METAL	20KAC	1	
VR2-4	3238088710	VR EVU E3J FK4 B54 50KB	50KB	3	
C14	3409210221-T	CAP AF RSG 1000UF 6.3V 10 P	1000/6.3	1	
C8-9 C18 C25 C27 C30	3409222071-T	CAP AF RSG 22UF 50V 5 P	22/50	6	
C32	3409222971-T	CAP AF RSG 2.2UF 50V 5 P	2.2/50	1	
C1-3	3409247081-T	CAP AF SG 47UF 63V 8 P	47/63	3	
C6-7 C10-11 C15 C28	3509101130-T	CAP CE SL 100PF 50V J	100P	6	
C12-13	3509221130-T	CAP CE SL 220PF 50V J	220P	2	
C4-5	3509271130-T	CAP CE SL 270PF 50V J	270P	2	
C37	3529103531-A		10000P	1	
C33-36	3509104530-T	CAP CE F 0.1UF 50V Z	0.1/50	4	
C16-17 C26 C29	3509470130-T	CAP CE SL 47PF 50V J	47P	4	
C19	3609152120-T	CAP MA 0.0015UF 100V J	0.0015/100(M)	1	
C20	3609332120-T	CAP MA 0.0033UF 100V	0.0033/100(M)	1	
C23	3609472120-T	CAP MA 0.0047UF 100V J	0.0047/100(M)	1	
C21-22 C31	3609473120-T	CAP MA 0.047UF 100V	0.047/100(M)	3	
CN2 CNA2	SP1243000210		YW025-05P	2	

LED DISPLAY B'D

CND2	SP1243000208		4P	1	
CND3	SP1243000207		5P	1	
CND1	SP1243000204		6P	1	
UD1 UD3 UD5	2118030405	KIA6966S	KIA6947S	3	
UD2 UD4 UD6	2118040105	KIA6967S	KIA6967S	3	
LDD1-3	2300030105 8545990810	LED LTL-1CHE-021A LITEON LED LIMITER PA-ALL	LED LAMP	3 3	
LDB1-3	2318999990	LED DISPLAY A42B/5G4YH	LEDBAR 10DOT A	3	
SWD1	3238098310	SW SLIDE SS90020-0202-6T-NN	SW SLIDE	1	
ZDF2	2058502240	DIODE ZENER UZ-24BM(1N5252B)	UZ 24BM	1	
RD4 RD7 RD11 RD14 RD18 RD21	3009101973	RES CF 100 1/5W J N	100	6	
RD2 RD9 RD16	3009203973	RES CF 20K 1/5W J N	20K	3	
RD24	3009472973	RES CF 4.7K 1/5W J N	4.7K	1	
RD5 RD12 RD19	3009473973	RES CF 47K 1/5W J N	47K	3	
RD1 RD8 RD15	3009512973	RES CF 5.1K 1/5W J N	5.1K	3	
RD22-23	3009562973	RES CF 5.6K 1/5W J N	5.6K	2	
RD6 RD13 RD20	3009563973	RES CF 56K 1/5W J N	56K	3	
RD3 RD10 RD17	3009823973	RES CF 82K 1/5W J N	82K	3	
RD25	3039102572-F	RES MO 1K 2W J N	1K 2W	1	
CD1-10	3409247972-T	CAP AF RSS 4.7UF 50V 5 P	4.7/50	10	

OUTPUT JACK B'D

CNJ5	SP1243000201		3P	1	
CNJ2	SP1243000202		4P	1	
CNJ1	SP1243000203		5P	1	
PJ1-8	4438192910	PHONE JACK (5P) METAL	5P	8	
XJ1-3	4408194310	XLR JACK (M) E503A0150N	E503A0150N	3	
TJ1	SP1243000211		1P	1	
CNJ3	SP1243000205		7P	1	
CNJ4	SP1243000206		8P	1	

POWER SUPPLY B'D

CNP1 CNP3	4428595003	LW5267/LWB0640/2.5MM-03P	3P	2	
CNP4	4428595004	LW5267/LWB0640/2.5MM-04P	4P	1	
CNP2	4428595005	LW5267/LWB0640/2.5MM-05P	5P	1	
FP1-2	5508112230	FUSE 51S 20MM 1A/250V K/U/C/J	1A/250V	2	
UP1	2168640988	IC 7815 SAMSUNG	7815	1	
QP1	2028406113	TR NPN KTD2058Y (D880Y)	KTD 2058Y	1	
BDP1	2058100976	DIODE BRIDGE KBP202G	KBPC 202G	1	
DP1-6	2058100996	DIODE RECTIFIER LT1N4006(T/R)	1N 4006	6	
ZDP1-2	2058502240	DIODE ZENER UZ-24BM	UZ 24BM	2	
UP2	2168640987	IC 7915 SAMSUNG	7915	1	
RP3	3009562973	RES CF 5.6K 1/5W J N	5.6K	1	
RP2	3009475973	RES CF 4.7K 1/5W J N	4.7K	1	
FRP1-2	3089479275	F25X-4.7 J (F.R)	FR 4.7	2	
RP1	3039100572	RES MO 10 2W J N	10 2W	1	
CP12	3408210191	CAP RSA 100UF 100V SNAP 13 P	100/100	1	
CP16	3408222232	CAP E SG 2200UF 16V 13 P	2200/16	1	
CP3 CP7	3408222261	CAP RSA 2200UF 35V SNAP 18 P	2200/35	2	
CP5 CP9	3409210141-T	CAP AF RSG 100UF 25V 6 P	100/25	2	
CP13	3409222081-T	CAP AF RSG 22UF 63V 6 P	22/63	1	
CP14	3409247081-T	CAP AF RSG 47UF 63V 8 P	47/63	1	
CP1-2 CP11 CP15	3509103530-T	CAP CE F 0.01UF 50V Z	0.01/50	4	
CP4 CP6 CP8 CP10 CP17	3509104530-T	CAP CE F 0.1UF 50V Z	0.1/50	5	

POWER SWITCH B'D

CS1	3549103107	CAP DE2F3KH103MA4B	10000P	1	
CNS1	4428593603	LOCK WAFER 2 LW-1143-03P	3P	1	
TS1-2	SP1243000212			2	

TS4	SP1243000213			1	
TS3	SP1243000214			1	
CNS(1)				1	
CNP(1)				1	
CNP(2)				1	
PEM(1)				1	
PT1			PT MX1243	1	
SP1	4648099310	POWER SWITCH (H8500VB)	POWER SW	1	

L-MASTER B'D

CL1 CL12 CL13	3409222141-T	CAP AF RSG 220UF 25V J 8 P	220/25	1	
CL2	3509271130-T	CAP CE SL 270PF 50V J	270P	1	
CL3 CL6 CL27 CL28	3509470130-T	CAP CE SL 47PF 50V J	47P	1	
CL4 CL5 CL7	3409247041-T	CAP AF RSG 47UF 25V 5 P	47/25	3	
CL8-11	3509330130-T	CAP CE SL 33PF 50V J	33P	1	
CL14 CL15 CL21 CL22	3509101130-T	CAP CE SL 100PF 50V J	100P	4	
CL16-19 CL29-30	3509104530-T	CAP CE F 0.1UF 50V Z	0.1/50	6	
CL20	3509103530-T	CAP CE F 0.01UF 50V Z	0.01/50	1	
CL23-26 CL31-32	3409222071-T	CAP AF RSG 22UF 50V 5 P	22/50	6	
CNL1	4428592820	WAFER BOX 20P TPHAB03-1419-20A	20P	1	
CNL2	4428592810	WAFER BOX 10P TPHAB03-1419-10A	10P	1	
CNL3	4428595007	LW5267/LWB0640/2.5MM-7P	7P	1	
FRL1-2	3089100275	F25X-10 J (F.R)	FR 10	1	
RL1 RL3	3009243973	RES CF 24K 1/5W J N	24K	2	
RL2	3009103973	RES CF 10K 1/5W J N	10K	1	
RL4 -7	3009472973	RES CF 4.7K 1/5W J N	4.7K 1%	4	
RL8 RL10-11 RL13	3002100953	RES CF 10K 1/5W F N	10K 1%	4	
RL9 RL12	3009750973	RES CF 75 1/5W JN	75	2	
RL14-15 RL17-20	3009473973	RES CF 47K 1/5W J N	47K	6	
RL16	3009101973	RES CF 100 1/5W J N	100	1	
RL21-22	3009123973	RES CF 12K 1/5W J N	12K	2	
RL23-24	3009272973	RES CF 2.7K 1/5W J N	2.7K	2	
RL25-26	3009183973	RES CF 18K 1/5W J N	18K	2	
RL27	3009203973	RES CF 20K 1/5W J N	20K	1	
UL1-3	2118010432	IC NJM2068DD JRC	NJM 2068D	3	
VRL1	3238081810	VR RA6040-30-15D1-A14-008	10KA	1	
VRL2	3238088410	VR EVJ C50 F02 A24 20KA*2	20KA*2	1	
VRL3		VR RV112B-20E1-175A-A/C24-0C (A/C20K)	20K	1	

R-MASTER B'D

CNR1	4428592820	WAFER BOX 20P TPHAB03-1419-20A	20P	1	
CR16-19 CR29-30	3509104530-T	CAP CE F 0.1UF 50V Z	0.1/50	6	
RR16	3009101973	RES CF 100 1/5W J N	100	1	
CR20	3509103530-T	CAP CE F 0.01UF 50V Z	0.01/50	1	
CR14-15 CR21-22	3509101130-T	CAP CE SL 100PF 50V J	100P	4	
RR2	3009103973	RES CF 10K 1/5W J N	10K	1	
RR8 RR10-11 RR13	3002100953	RES CF 10K 1/5W F N	10K 1%	4	
VRR1	3238081810	VR RA6040-30-15D1-A14-008	10KA	1	
RR21-22	3009123973	RES CF 12K 1/5W J N	12K	2	
RR25-26	3009183973	RES CF 18K 1/5W J N	18K	2	
RR23-24	3009272973	RES CF 2.7K 1/5W J N	2.7K	2	
RR27	3009203973	RES CF 20K 1/5W J N	20K	1	
VRR2	3238088410	VR EVJ C50 F02 A24 20KA*2	20KA*2	1	
VRR3		VR RV112B-20E1-175A-A/C24-0C (A/C20K)	20KAC	1	
CR23-26 CR31-32	3409222071-T	CAP AF RSG 22UF 50V 5 P	22/50	6	
CR1 CR12-13	3409222141-T	CAP AF RSG 220UF 25V J 8 P	220/25	3	
RR1 RR3	3009243973	RES CF 24K 1/5W JN CDC-9300	24K	2	
CR2	3509271130-T	CAP CE SL 270PF 50V J	270P	1	
RR9 RR12	3009750973	RES CF 75 1/5W J N	75	2	
CR8-11	3509330130-T	CAP CE SL 33PF 50V J	33P	4	
RR4-7	3009472973	RES CF 4.7K 1/5W J N	4.7K 1%	4	
CR4-5 CR7	3409247041-T	CAP AF RSG 47UF 25V 5 P	47/25	3	

RR14-15 RR17-20	3009473973	RES CF 47K 1/5W J N	47K	6	
CR3 CR6 CR27-28	3509470130-T	CAP CE SL 47PF 50V J	47P	4	
CNR2	4428592810	WAFER BOX 10P TPHAB03-1419-10A	10P	1	
CNR3	4428595008	LW5267/LWB0640/2.5MM-8P	8P	1	
FRR1-2	3089100275	RES NFR 10 1/4W J R PHILKO	FR 10	2	
UR1-3	2118010432	IC NJM2068DD JRC	NJM 2068DD	3	

MONO-MASTER B'D

CNM1	4428592820	WAFER BOX 20P TPHAB03-1419-20A	20P	1	
CNM3	4428595003	LW5267/LWB0640/2.5MM-03P	3P	1	
CNM4	4428595005	LW5267/LWB0640/2.5MM-05P	5P	1	
SWM1-2	4628983710	SW PUSH JPS 2254AS JAEIL	JPS2254A	2	
UM1-4	2118010432	IC NJM2068DD JRC	NJM2068DD	4	
RM22 RM24-25 RM27	3002100953	RES CF 10K 1/5W F N	10K 1%	4	
RM17	3009101973	RES CF 100 1/5W J N	100	1	
RM6 RM12 RM23 RM26	3009750973	RES CF 75 1/5W J N	75	4	
RM2 RM8	3009183973	RES CF 18K 1/5W J N	18K	2	
RM13 RM15	3009103973	RES CF 10K 1/5W J N	10K	2	
RM4 RM10	3009104973	RES CF 100K 1/5W J N	100K	2	
RM16	3009123973	RES CF 12K 1/5W J N	12K	1	
RM1 RM7	3009243973	RES CF 24K 1/5W J N	24K	2	
RM3 RM9 RM30 RM31	3009823973	RES CF 82K 1/5W J N	82K	4	
RM5 RM11	3009363973	RES CF 36K 1/5W J N	36K	2	
RM18-21	3009472973	RES CF 4.7K 1/5W J N	4.7K 1%	4	
RM14 RM28-29	3009473973	RES CF 47K 1/5W J N	47K	3	
FRM1-2	3089100275	F25X-10 J (F.R)	FR 10	2	
VRM3	3238081810	VR RV0640-30-15D1-A14 ALPHA	10KA	1	
VRM1-2	3238088610	VR RV09B-20E1-175F-A24 (A20K)	20KA	2	
CM1 CM10 CM19 CM34 CM35	3409222141-T	CAP AF RSG 220UF 25V J 8 P	220/25	5	
CM6 CM7 CM9 CM15-16 CM18 CM24-25 CM27	3409247041-T	CAP AF RSG 47UF 25V 5 P	47/25	9	
CM36-37	3509101130-T	CAP CE SL 100PF 50V J	100P	2	
CM4-5 CM13-14 CM22-23 CM28-29	3509104530-T	CAP CE F 0.1UF 50V Z	0.1/50	8	
CM2 CM11 CM20	3509271130-T	CAP CE SL 270PF 50V J	270P	3	
CM30-33	3509330130-T	CAP CE SL 33PF 50V J	33P	3	
CM3 CM8 CM12 CM17 CM21 CM26	3509470130-T	CAP CE SL 47PF 50V J	47P	1	
CNM2	4428592810	WAFER BOX 10P TPHAB03-1419-10A	10P	1	

PFL MONITOR B'D

CF4-5 CF13-14 CF22-23 CF36	3509104530-T	CAP CE F 0.1UF 50V Z	0.1/50	7	
CF2 CF11 CF20 CF28-29	3509271130-T	CAP CE SL 270PF 50V J	270P	5	
CF3 CF8 CF12 CF17 CF21 CF24 CF32-33	3509470130-T	CAP CE SL 47PF 50V J	47P	8	
CNF2	4428592810	WAFER BOX 10P TPHAB03-1419-10A	10P	1	
CNF1	4428592820	WAFER BOX 20P TPHAB03-1419-20A	20P	1	
CNF3	4428595003	LW5267/LWB0640/2.5MM-03P	3P	1	
CNF6	4428595004	LW5267/LWB0640/2.5MM-04P	4P	1	
CNM5	4428595005	LW5267/LWB0640/2.5MM-05P	5P	1	
CNF4	4428595006	LW5267/LWB0640/2.5MM-06P	6P	1	
CF26-27	3409222071-T	CAP AF RSG 22UF 50V 5 P	22/50	2	
CF1 CF10 CF19 CF34-35	3409222141-T	CAP AF RSG 220UF 25V J 8 P	220/25	5	
CF39	3409247971-T	CAP AF RSG 4.7UF 50V 5 P	4.7/50	1	
CF6-7 CF9 CF15-16 CF18 CF25 CF30-31	3409247041-T	CAP AF RSG 47UF 25V 5 P	47/25	9	
UF1-3	2118010432	IC NJM2068DD JRC	NJM 2068D	3	
PJF1	4438097310	JACK PHONE 4P	4P	1	
VRF1-2	3238088610	VR EVU E2J FK4 A24 20KA	20KA	2	
VRF3	3238088410	VR EVJ C50 F02 A24 20KA*2	20KA *2	1	
UF4	2118010932	IC NJM 4556AD	NJM 4556	1	

RF4 RF10 RF16	3009104973	RES CF 100K 1/5W J N	100K	3	
RF30-31	3009104973	RES CF 100K 1/5W J N	100K	2	
RF6 RF12	3009750973	RES CF 75 1/5W J N	10	2	
FRF1-4	3089100275	RES NFR 10 1/4W J R PHILKO	FR 10	4	
RF14 RF26	3009103973	RES CF 10K 1/5W J N	10K	2	
RF15	3009682973	RES CF 6.8K 1/5W J N	6.8K	1	
RF25	3009153973	RES CF 15K 1/5W J N	15K	1	
RF2 RF8 RF13	3009183973	RES CF 18K 1/5W J N	18K	2	
RF3 RF9 RF28 RF29	3009823973	RES CF 82K 1/5W J N	82K	4	
RF1 RF7	3009243973	RES CF 24K 1/5W J N	24K	2	
RF17-18	3009202973	RES CF 2K 1/5W J N	2K	2	
RF27	3009331973	RES CF 330 1/5W J N	330	1	
RF20-21	3039151472-T	RES MO 150 1W JN	150	2	
RF5 RF11	3009363973	RES CF 36K 1/5W J N	36K	2	
RF23-24	3009473973	RES CF 47K 1/5W J N	47K	2	
RF19 RF22	3009123973	RES CF 12K 1/5W J N	12K	2	
KF1	5528001040	RELAY RZ-24 RY-24W	RY-24	1	
SWF1-2	4628983710	SW PUSH JPS2254A JAEIL(NON SHORT)	JPS2254A	2	
QF1	2008606104-T	TR NPN KTC3198Y	KTC 3198Y	1	
ZDF1	2058502240	DIODE ZENER UZ-24BM	UZ 24BM	1	

ASS'Y

AC CORD	4308997310	AC CORD DOME 3-CORES			B
	4308999410	AC CORD V+VII6A-250VHOVV-F3G			C
	4308996710	AC CORD (WITHOUT PLUG)			D
	4308998000	AC CORD POWER FOR SAA			E
	4308999310	AC CORD UL 3 (INLET)			E
FUSE	5508211630				
	5508411434	FUSE TS 20MM 315MA/250V U/C/S			B,C,D
	5508111933				E

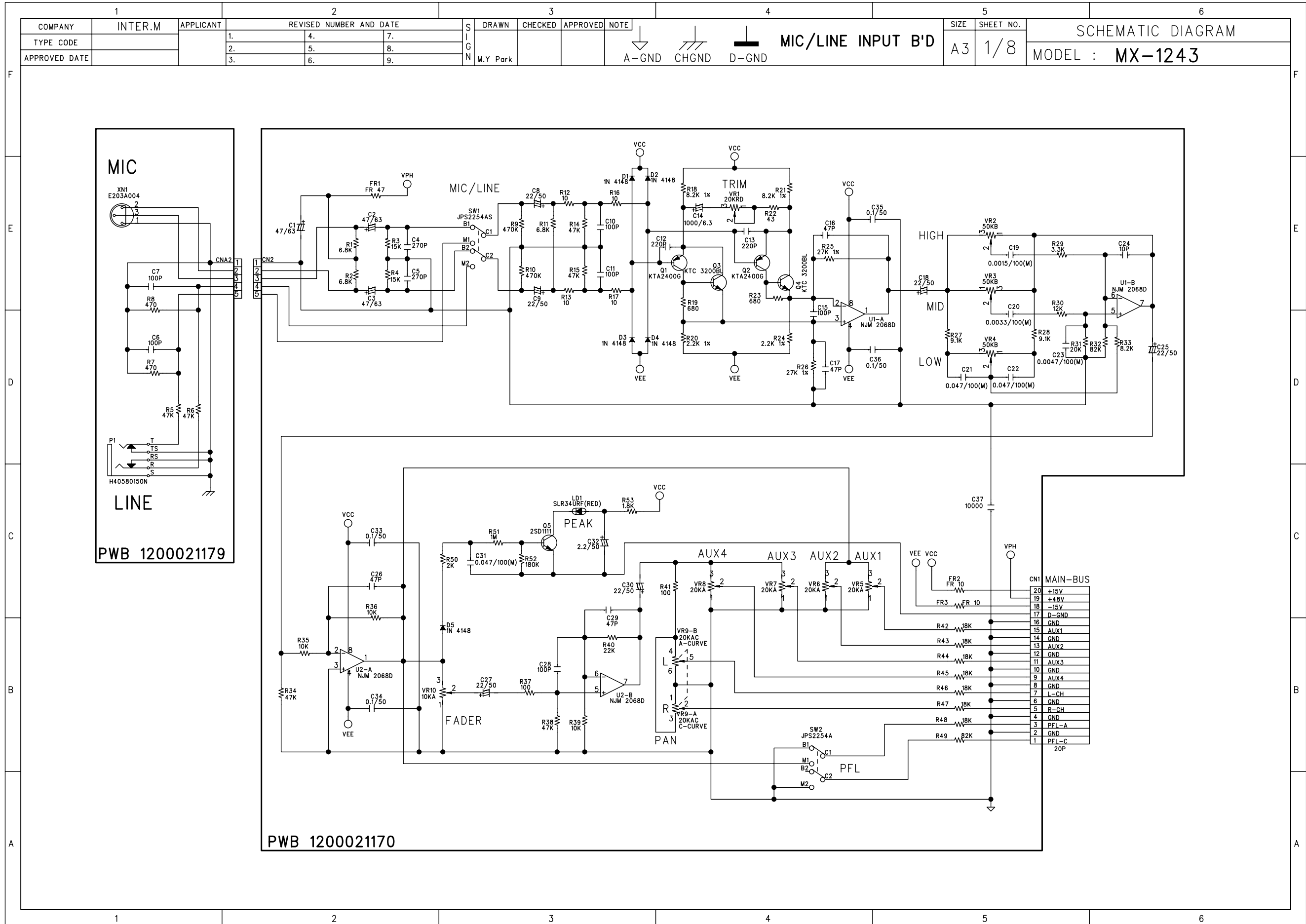

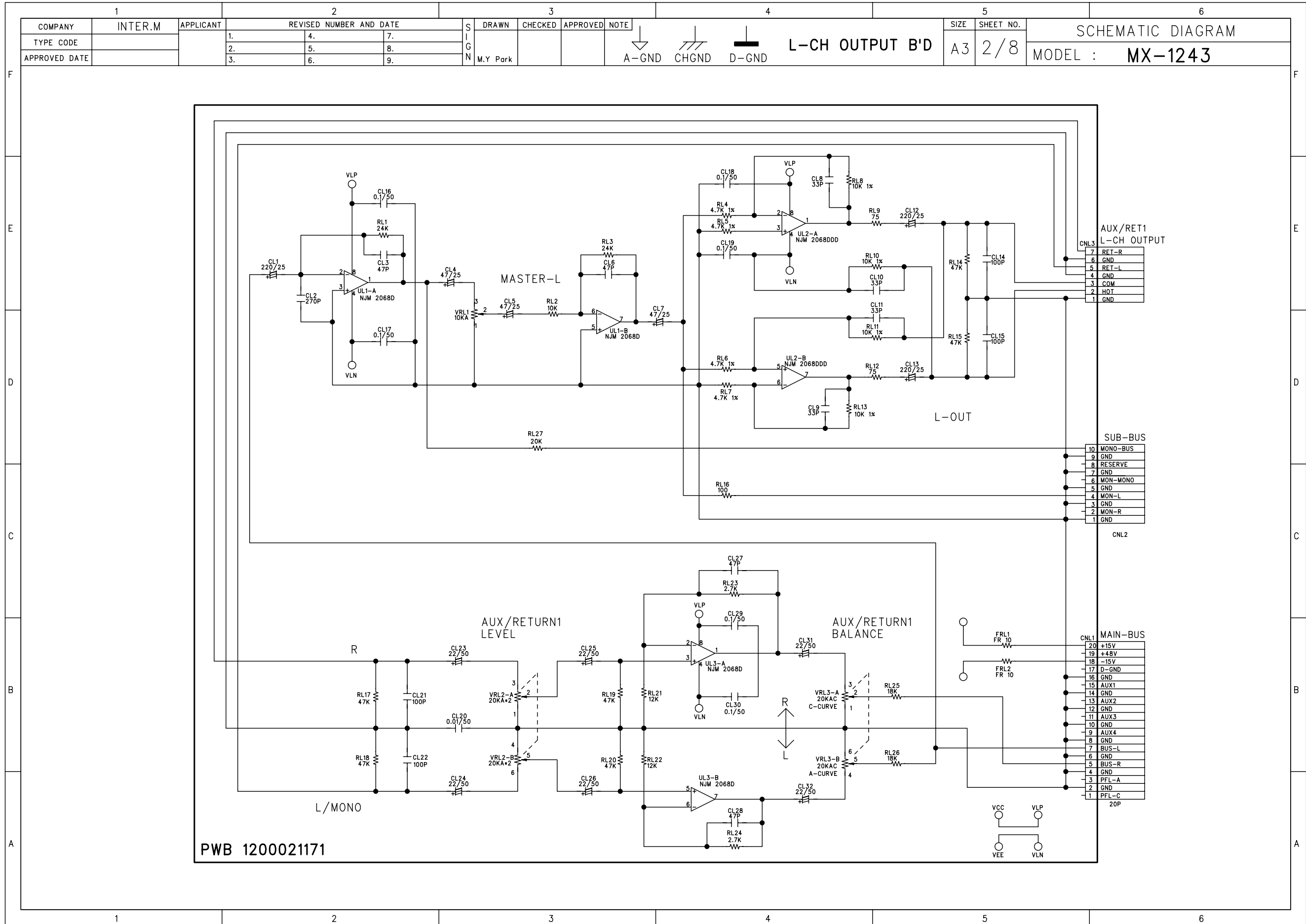

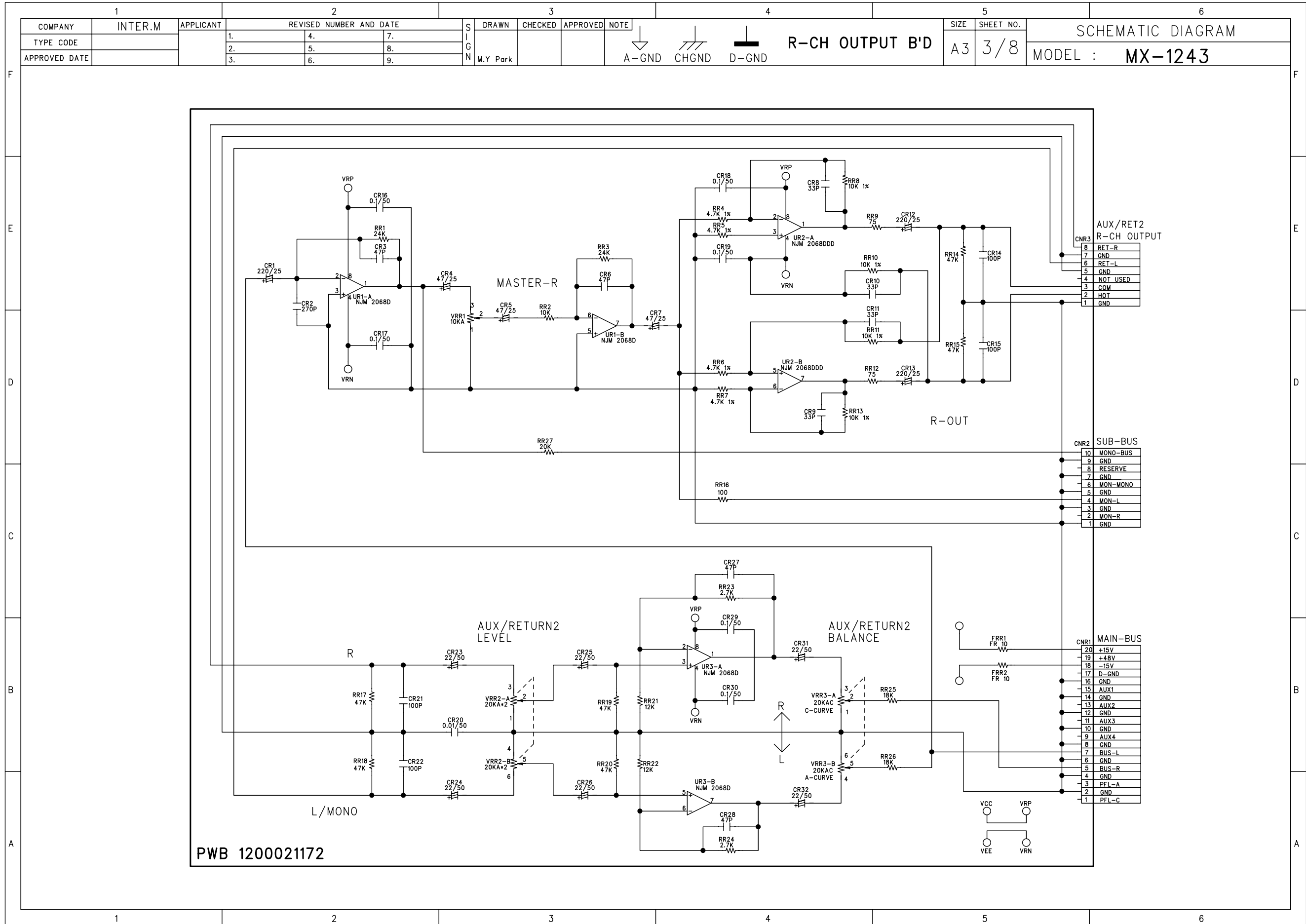

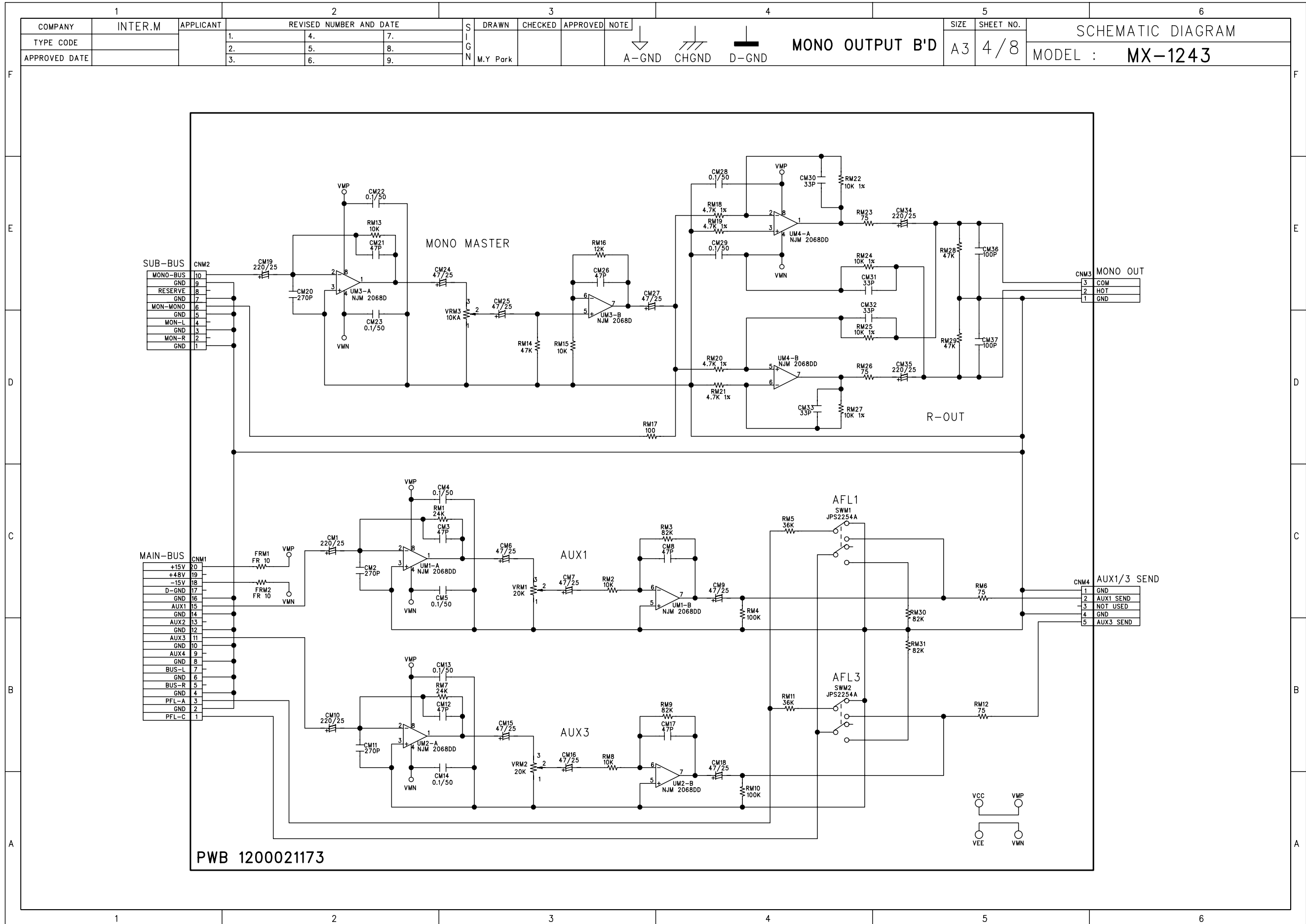

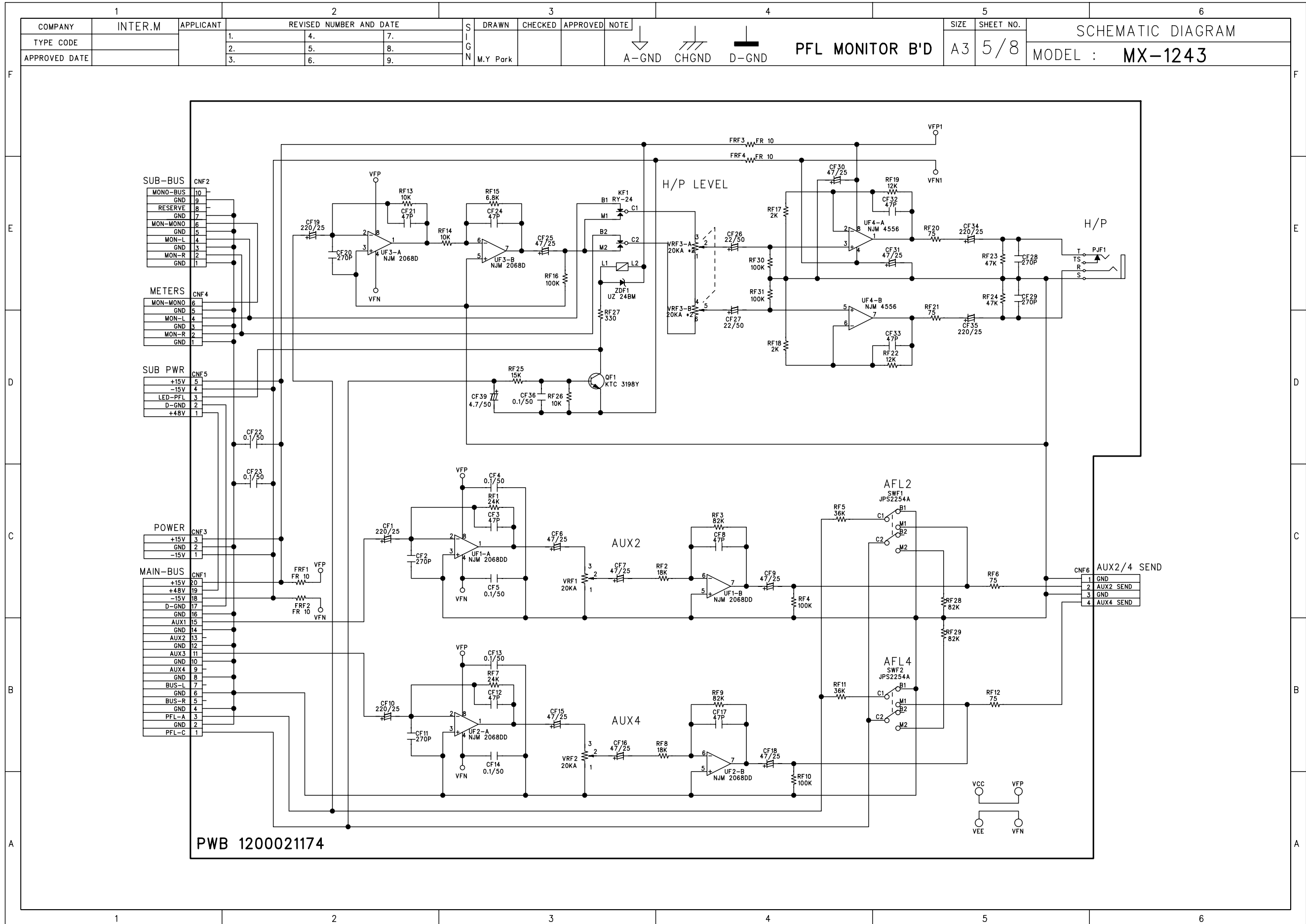

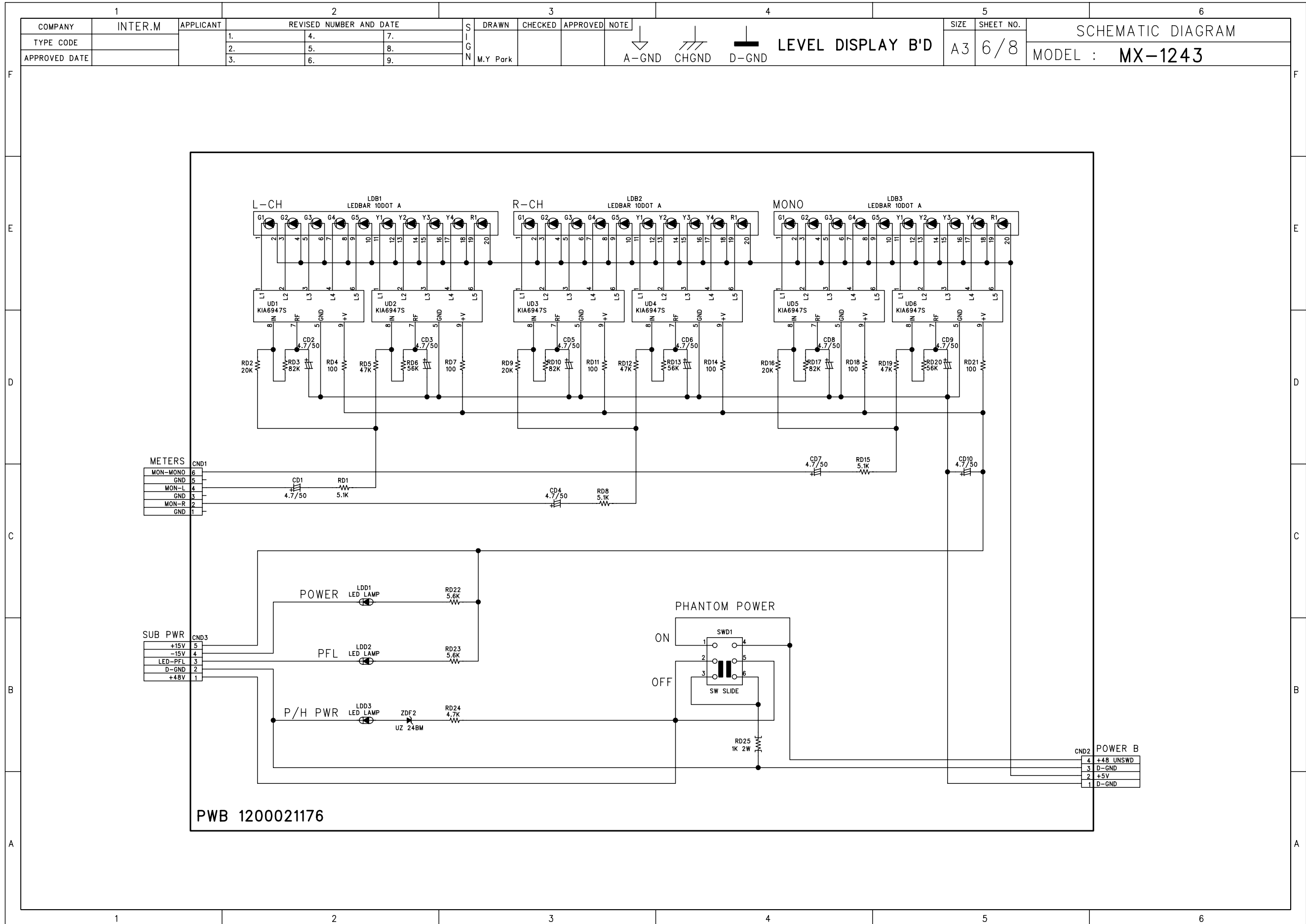

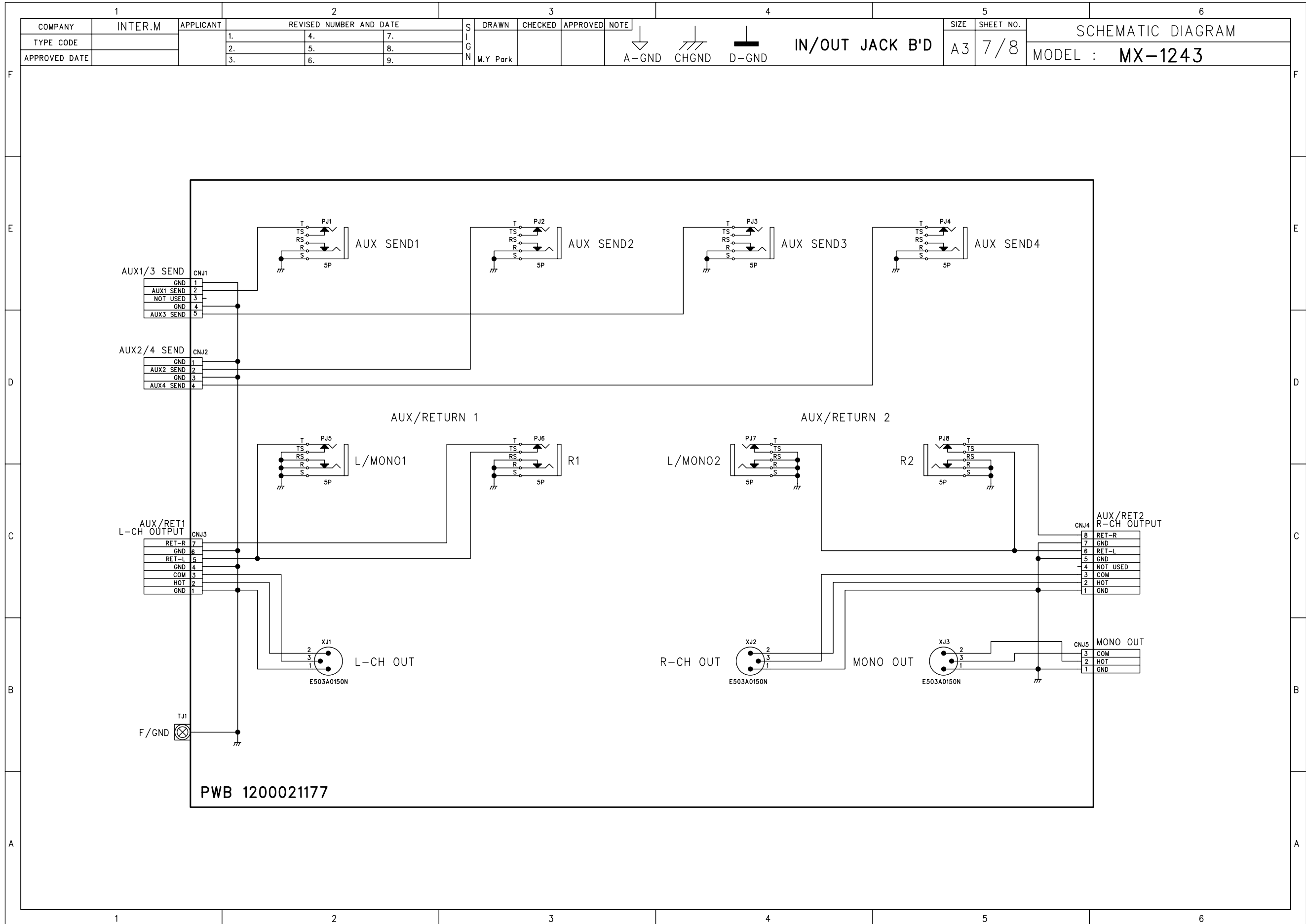

1		2			3		4		5		6	
COMPANY	INTER.M	APPLICANT	REVISED NUMBER AND DATE			SIGN	DRAWN	CHECKED	APPROVED	NOTE	SIZE	SHEET NO.
TYPE CODE			1.	4.	7.	M.Y Park				A-GND CHGND D-GND	A3	8/8
APPROVED DATE			2.	5.	8.							
			3.	6.	9.							
											SCHEMATIC DIAGRAM	
											MODEL : MX-1243	

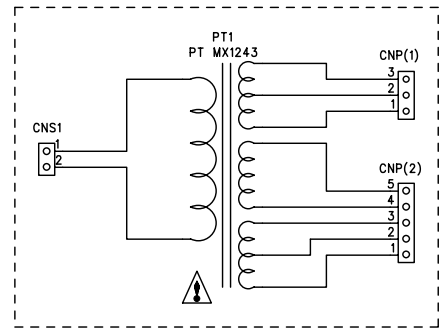
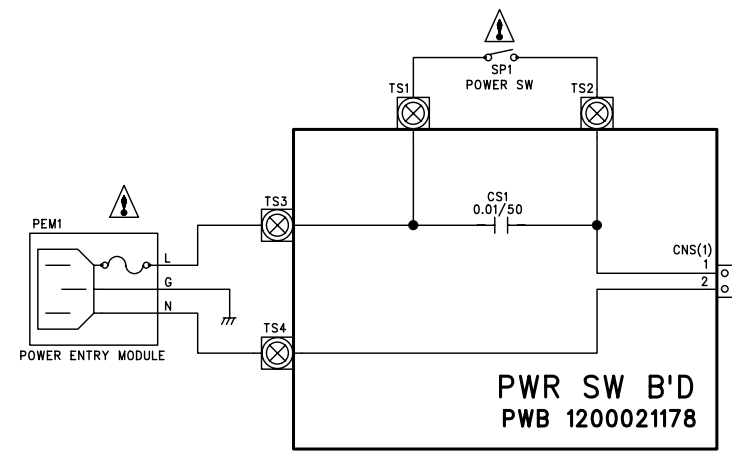
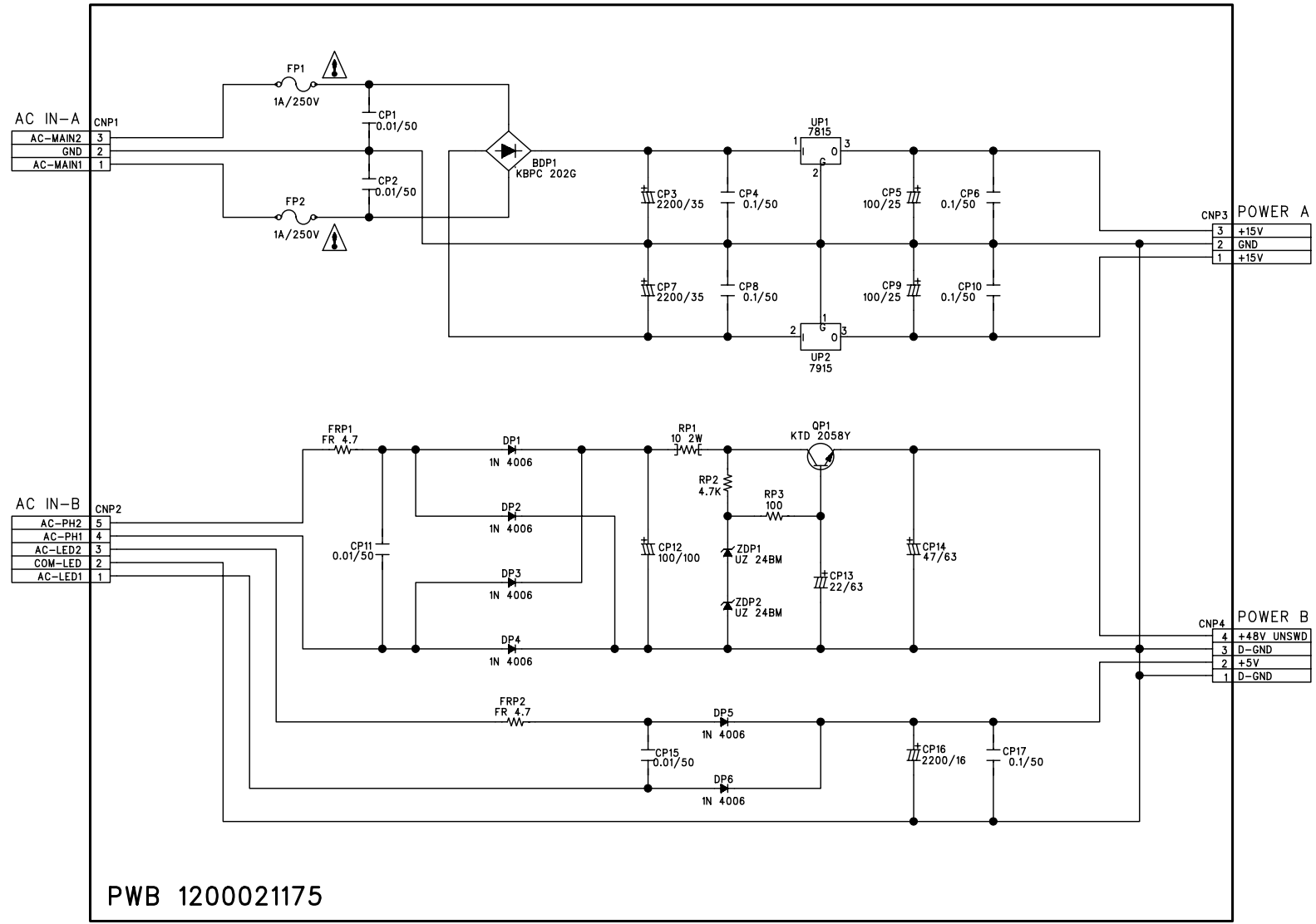

***SERVICE INFORMATION**

- RESISTANCE VALUES ARE INDICATED IN OHMS UNLESS OTHERWISE SPECIFIED. (K=1.000, M=1.000.000)
- CAPACITANCE VALUES ARE SHOWN IN MICROFARADS UNLESS OTHERWISE NOTED. (P=MICRO-MICROFARADS)
- ALL VOLTAGES ARE REFERED TO GROUND UNDER THE FOLLOWING CONDITIONS.
DC:NO SIGNAL EXCEPT WHERE INDICATED.
AC:RMS
- PRECAUTION-
 - ALL COMPONENTS MARKED MUST BE REPLACED ONLY WITH ORIGINAL TYPE SPECIFIED BY THE MANUFACTURER. INTER M CORPORATION AND INSTALLED AS THE ORIGINAL SPACERS AND POSITIONED AWAY FORM ADJACENT COMPONENTS WHERE APPLICABLE.
 - ALL SOLDERING MUST BE DONE IN A PROFESSIONAL MANNER USING SOLDER WHITE RESINE CORE ONLY.
 - ALL COVERS, SHIELD AND INSULATING SPACERS MUST BE REPLACED BEFORE RETURING APPLIANCE TO CUSTOMER.
 - A DAMAGE POWER SUPPLY CORD MUST BE REPLACED BEFORE RETURING TO CUSTOMER.
 - DIELECTRIC TEST CONSISTING OF 120V AC 60HZ IS TO BE APPLIED BETWEEN BOTH BALDES OF THE POWER SUPPLY CORD ATTACHMENT PLUG THE EXPOSE CONDUCTIVE SURFACE OF THE APPLIANCE FOR A PERIOD OF NOT LESS THAN ONE SECOND BEFORE RETURING APPLIANCE TO CUSTOMER.